



VELUX daylight Symposium 2019

Exploring the role of daylight in Architecture

Hugh Dutton Associés

Designing in Natural Light

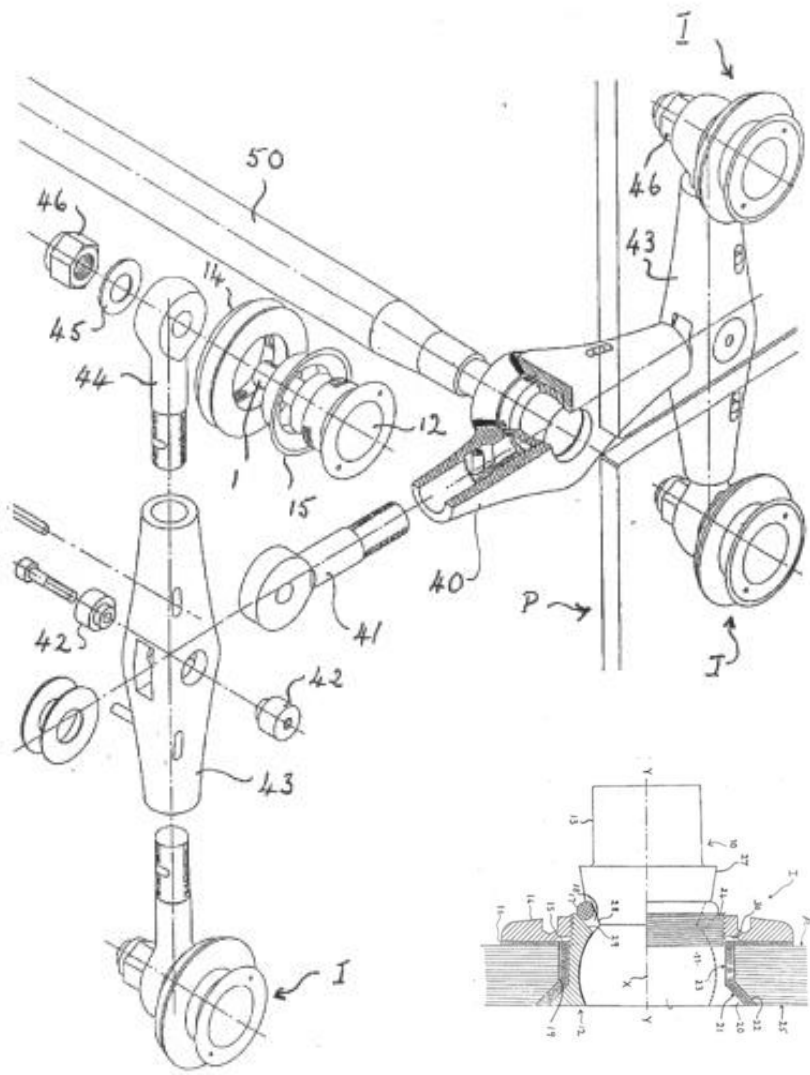
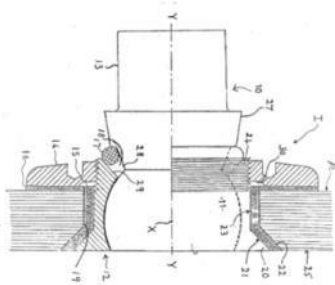
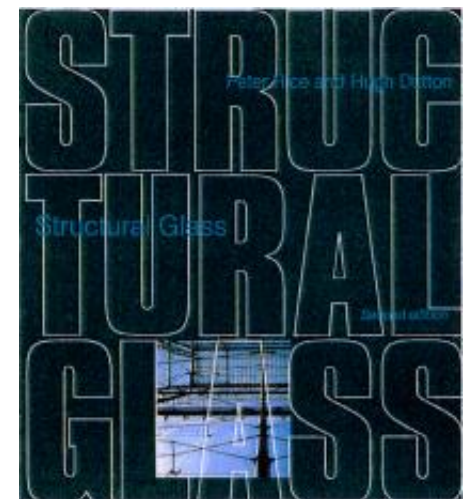

Fig. 1



Cité des Sciences, La Villette (1982-86)
Monumental Greenhouses
 Architect e: Adrien Faunsilber, Ingenieurs : RFR, Entreprise: CFEM (now Eiffel)



Stansted Airport
Architect : Norman Foster



Facade Ouest Cathedral de Lille (1991-2000)

Architects: Carlier, Artist Kinjo, Arch design Peter Rice and Hugh Dutton
Engineering: RFR, Contractor : Eiffel

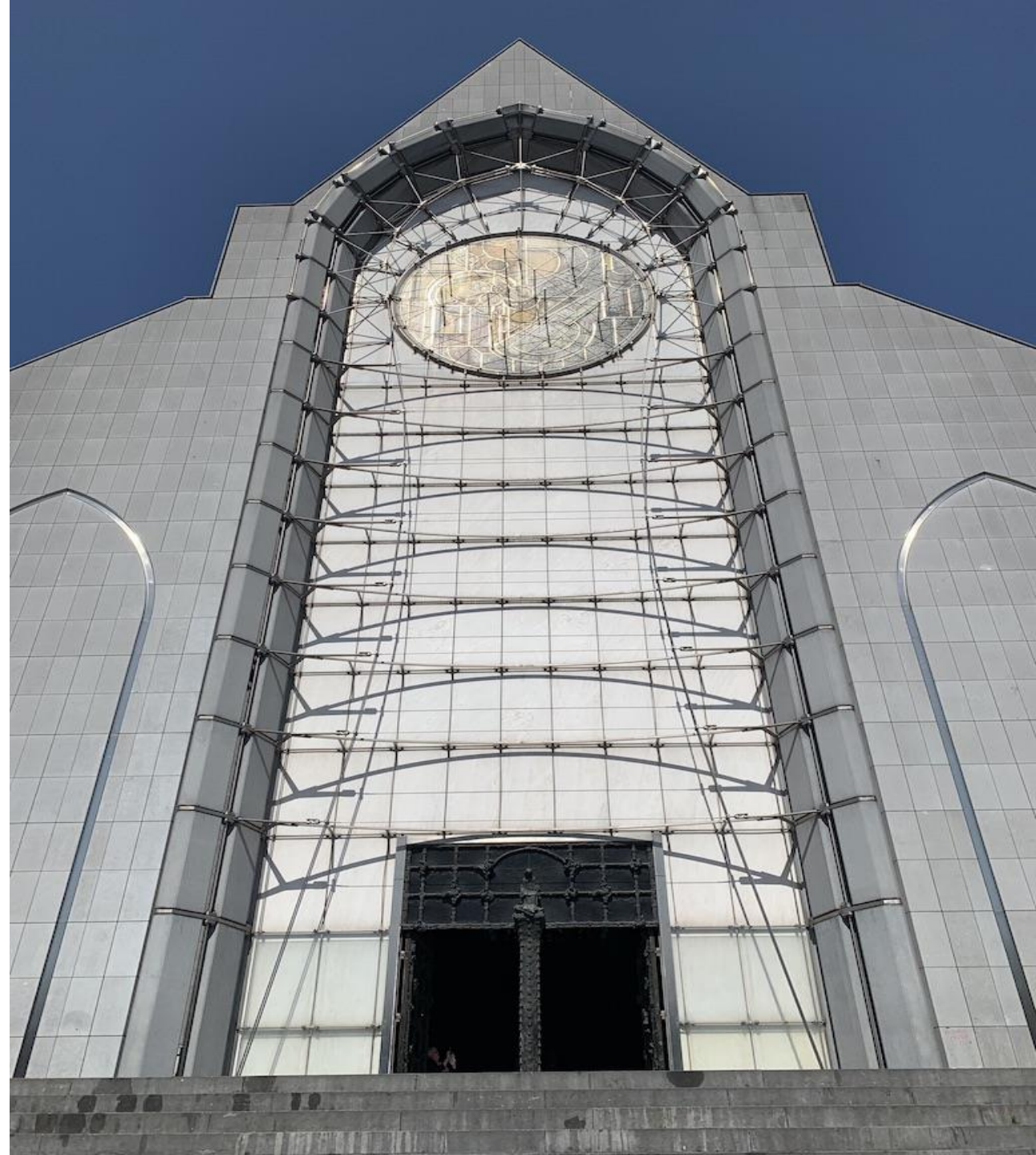



Facade Ouest Cathedral de Lille (1991-2000)

Architects: Carlier, Artist Kinjo, Arch design Peter Rice and Hugh Dutton
Engineering: RFR, Contractor: Eiffel







Louvre Museum

Grand Louvre, Paris



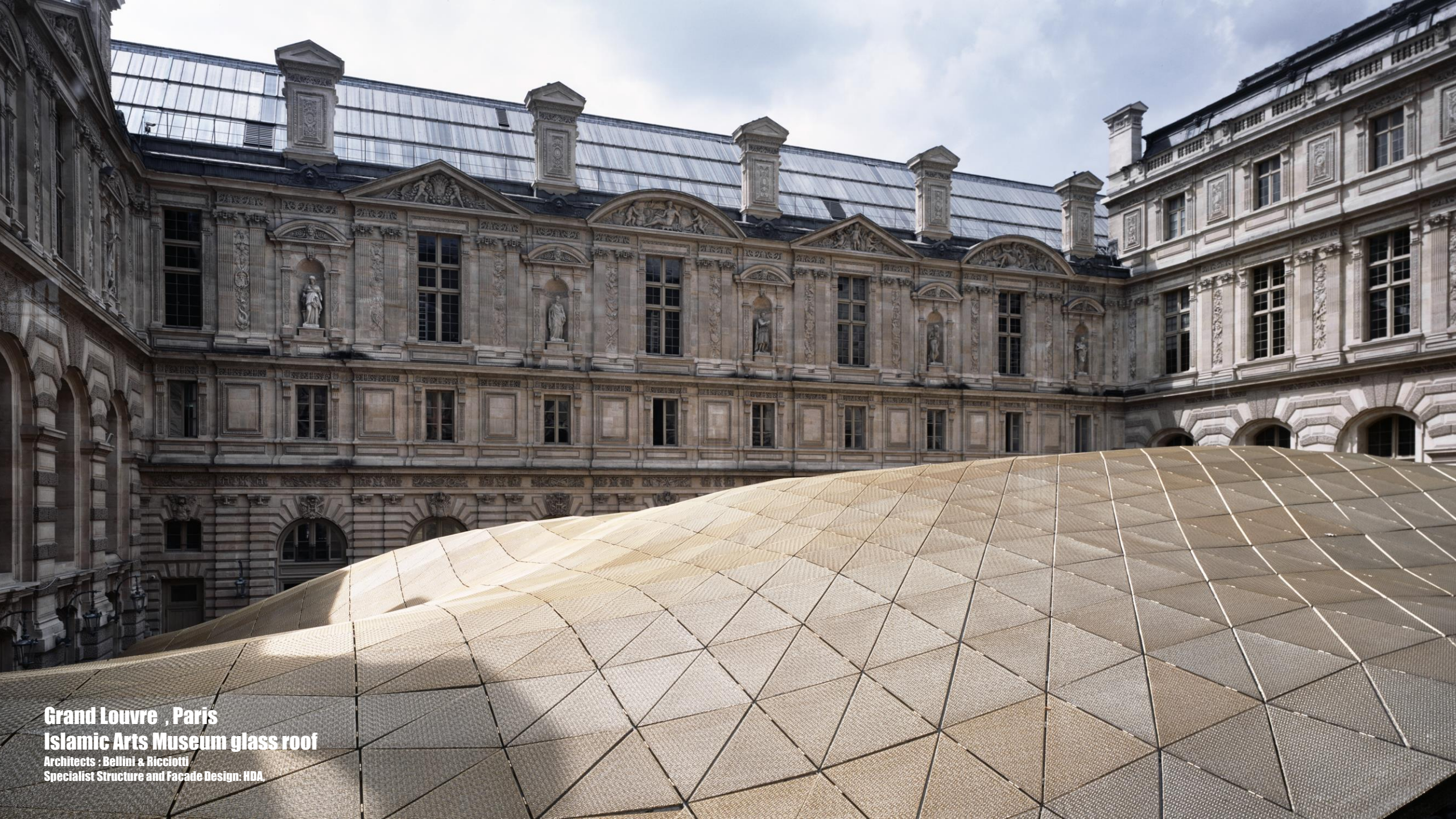

Grand Louvre , Paris
Islamic Arts Museum glass roof
Architects : Bellini & Ricciotti
Specialist Structure and Facade Design: HDA

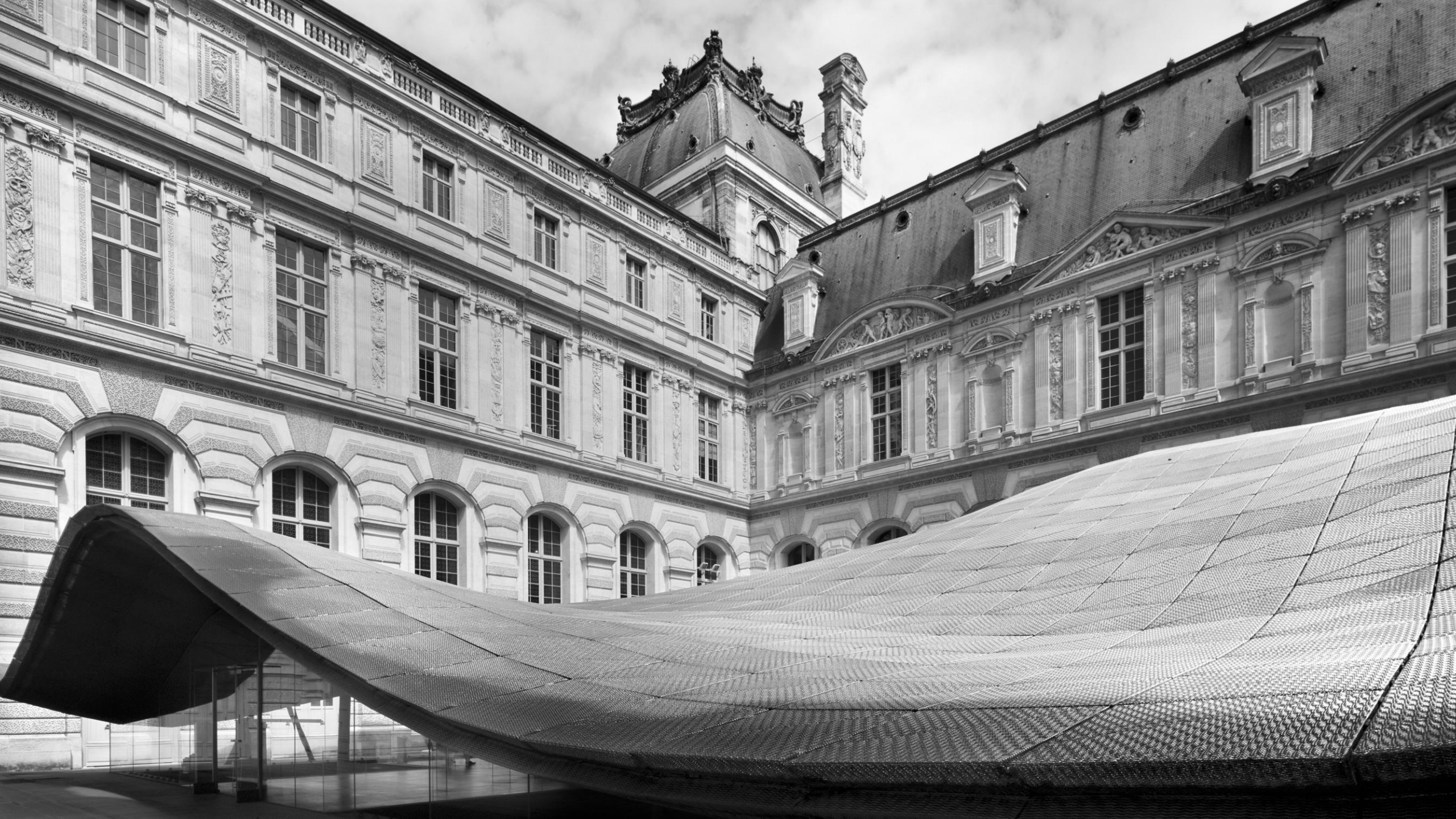

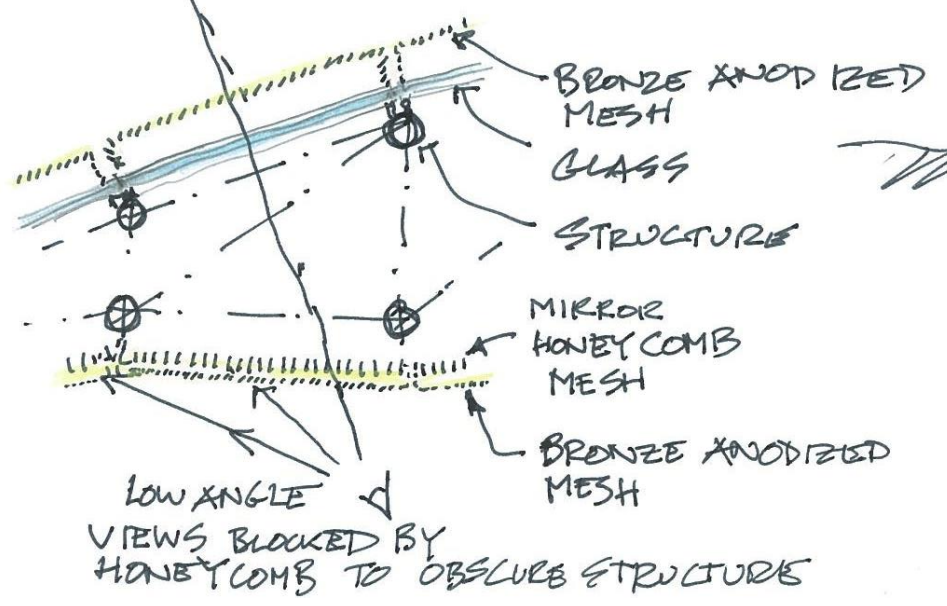
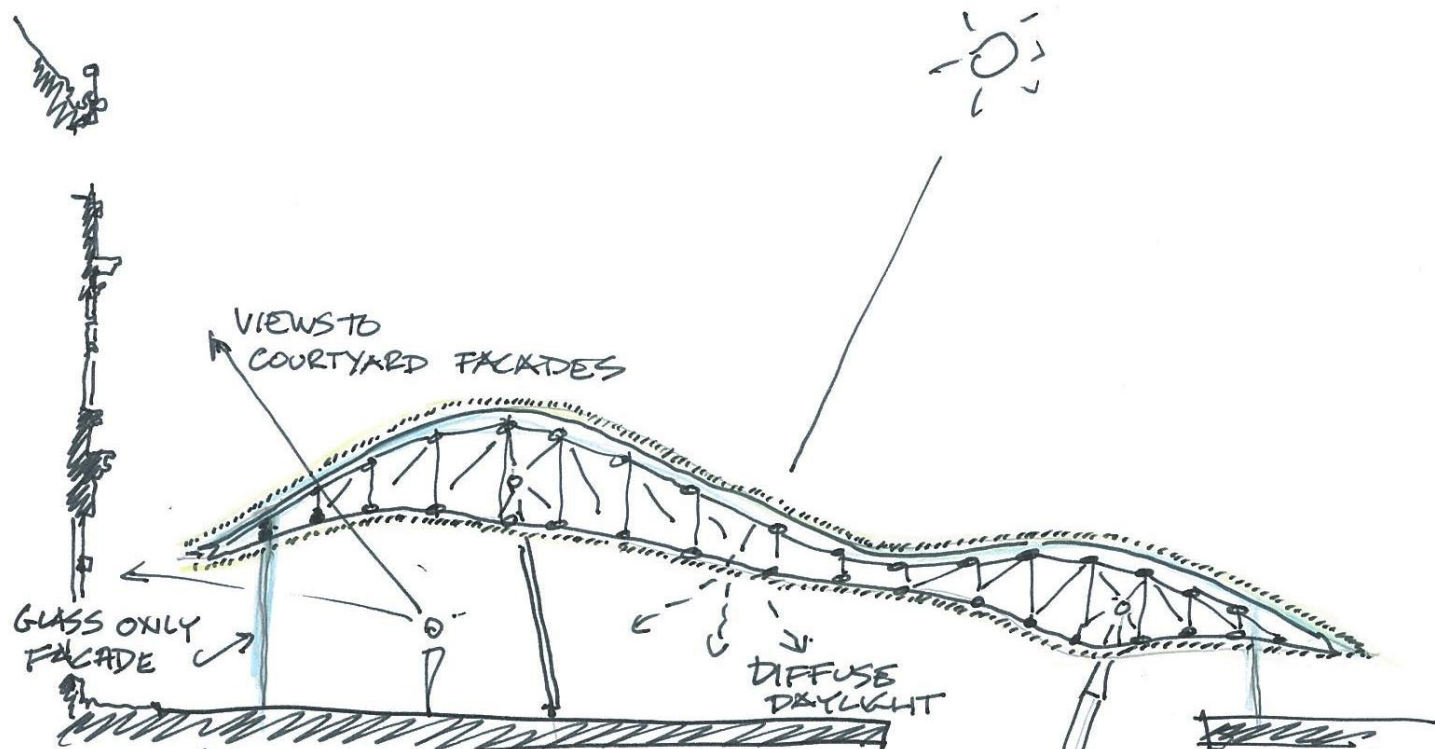

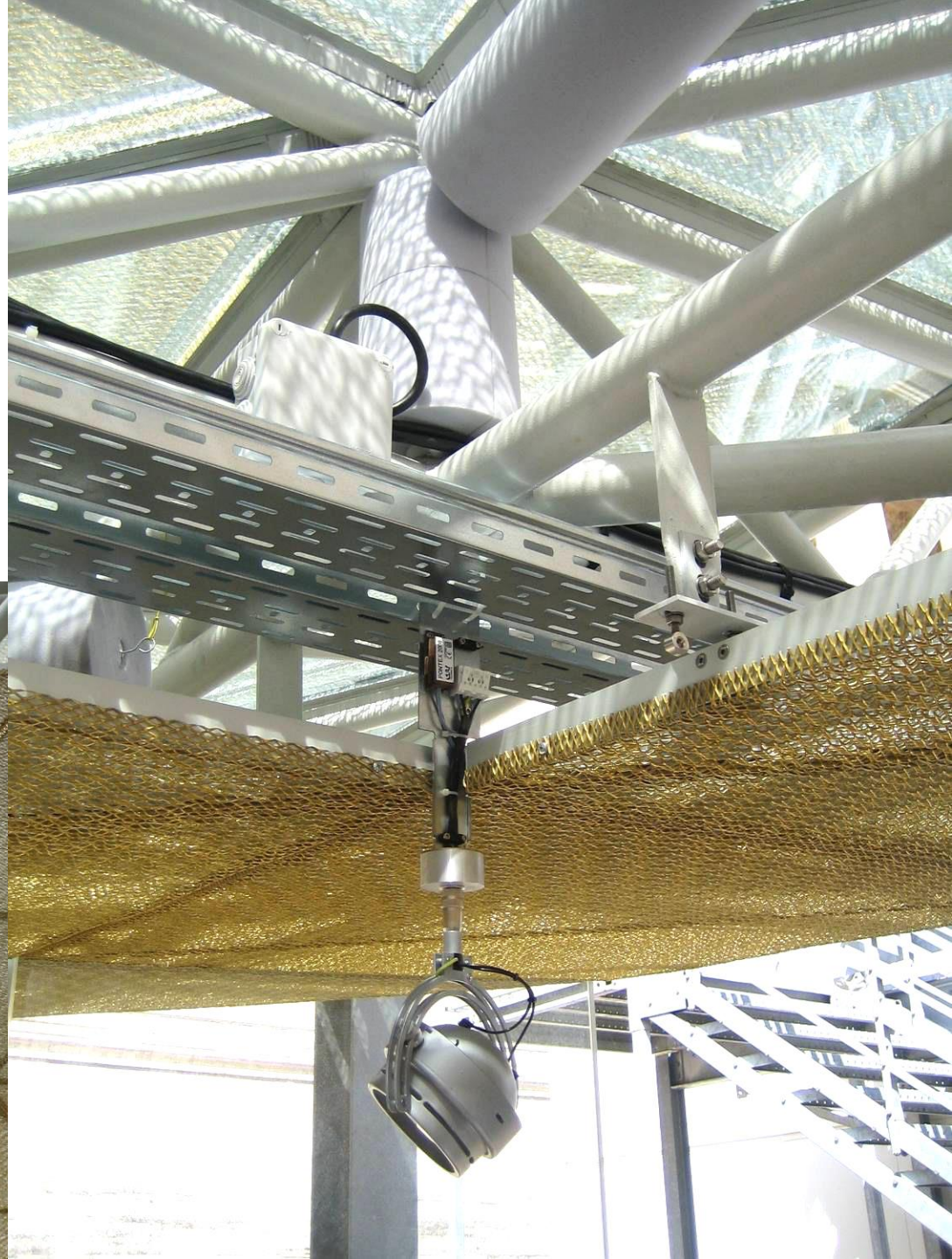
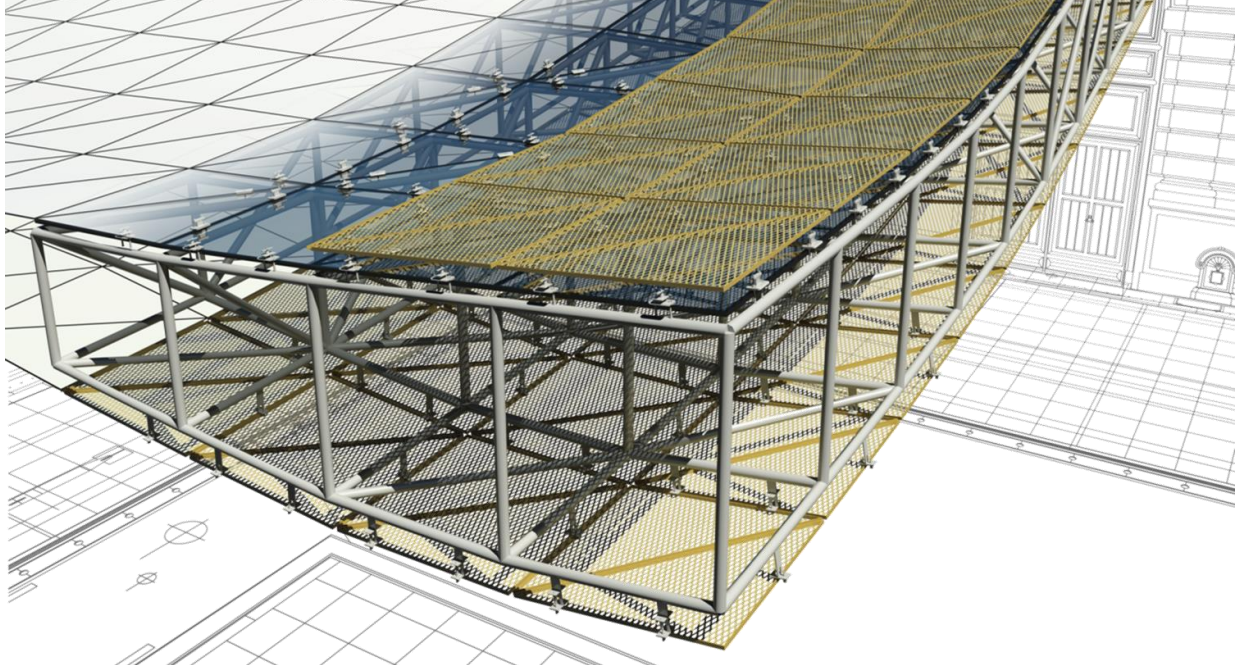

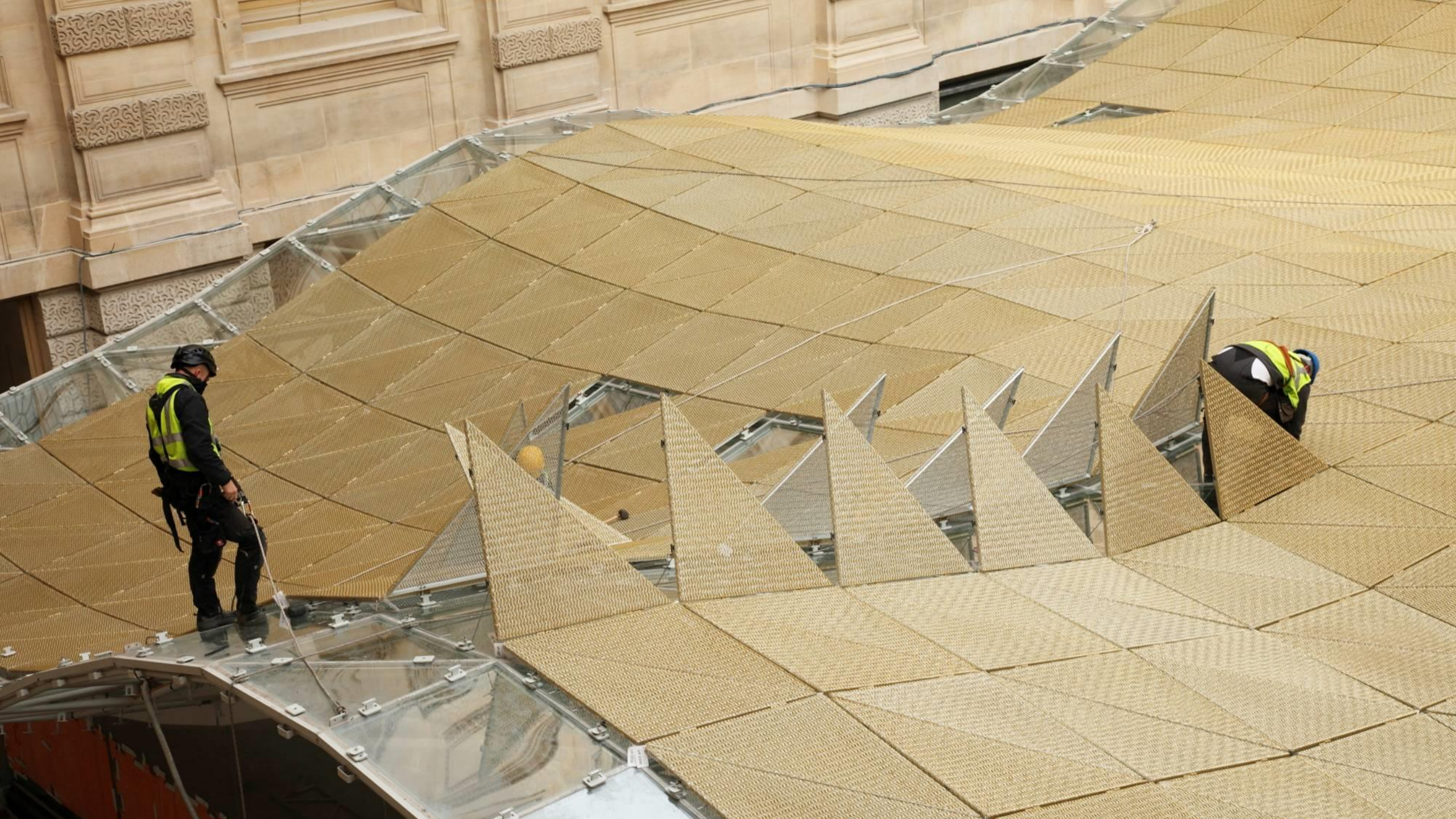

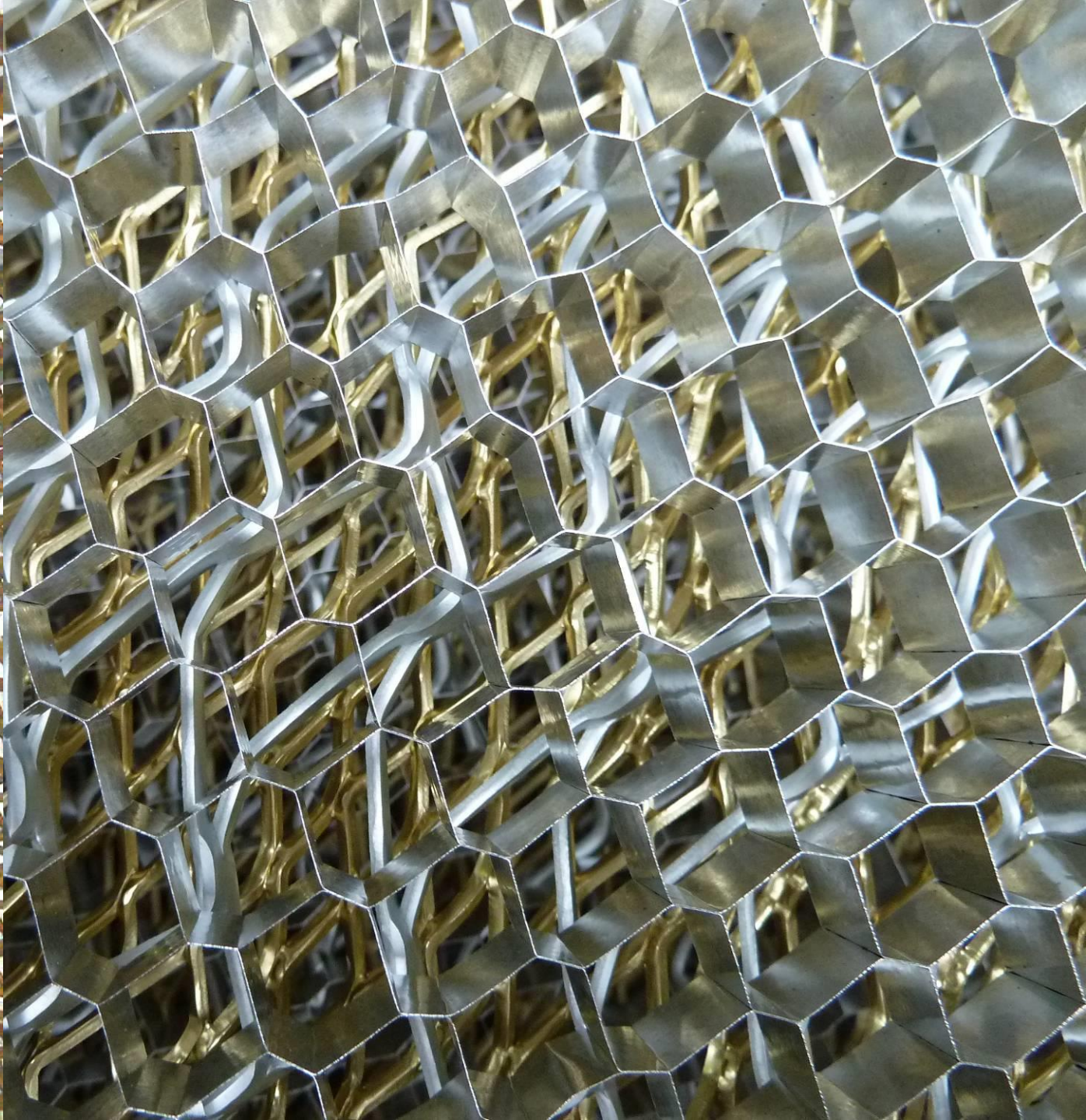
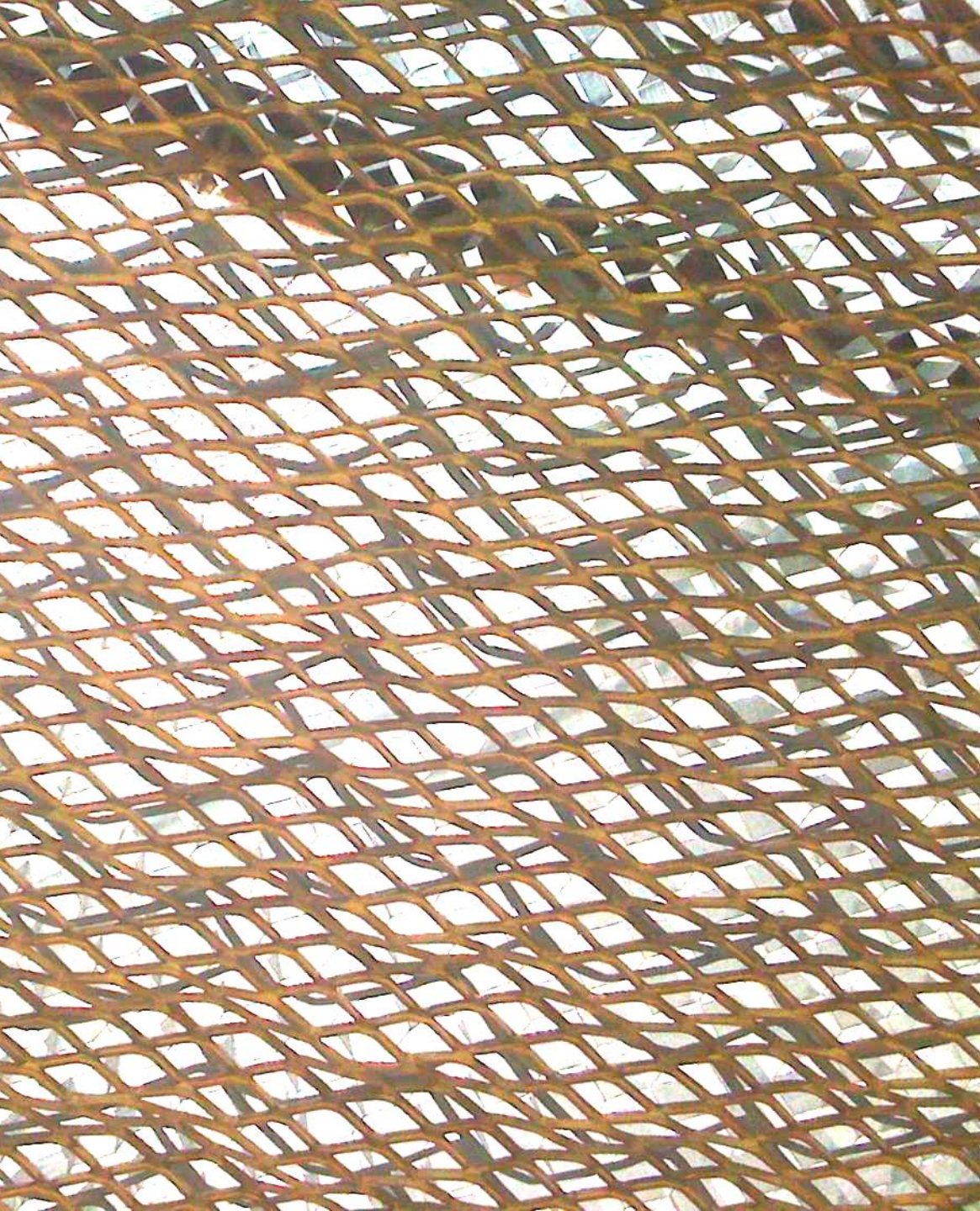











Germogli, Italy

designer : Hugh Dutton Associés
Contractor: Tecnopali

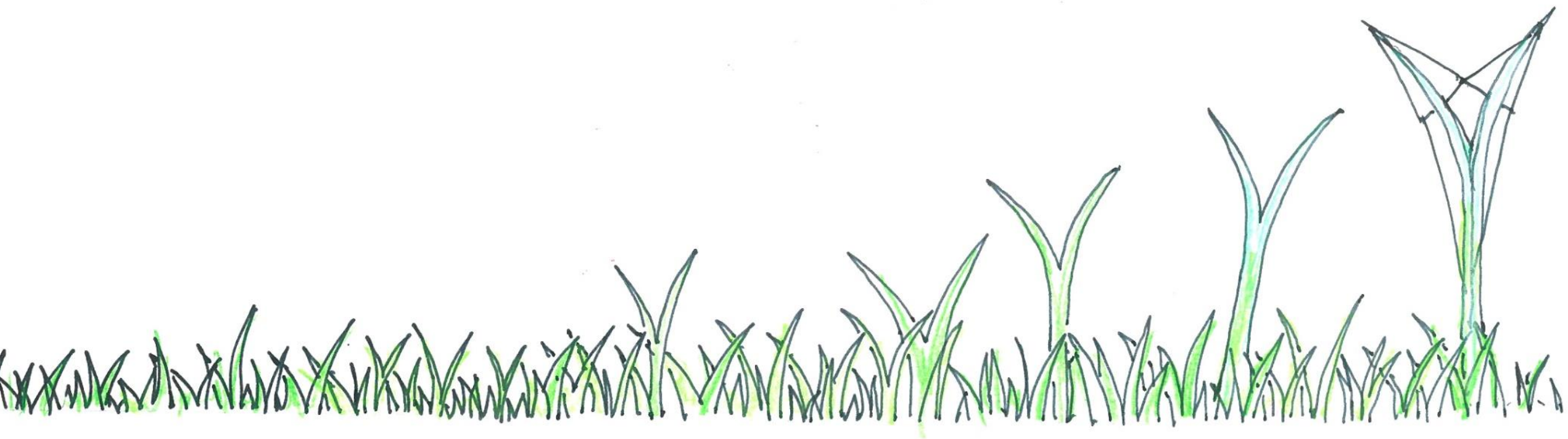





Climate Ribbon Brickell City Centre – Swire Properties

Architect: Arqitectura
Climate Ribbon Designer: HDA
Engineers: MKA
Climate Ribbon Contractor: Gartner

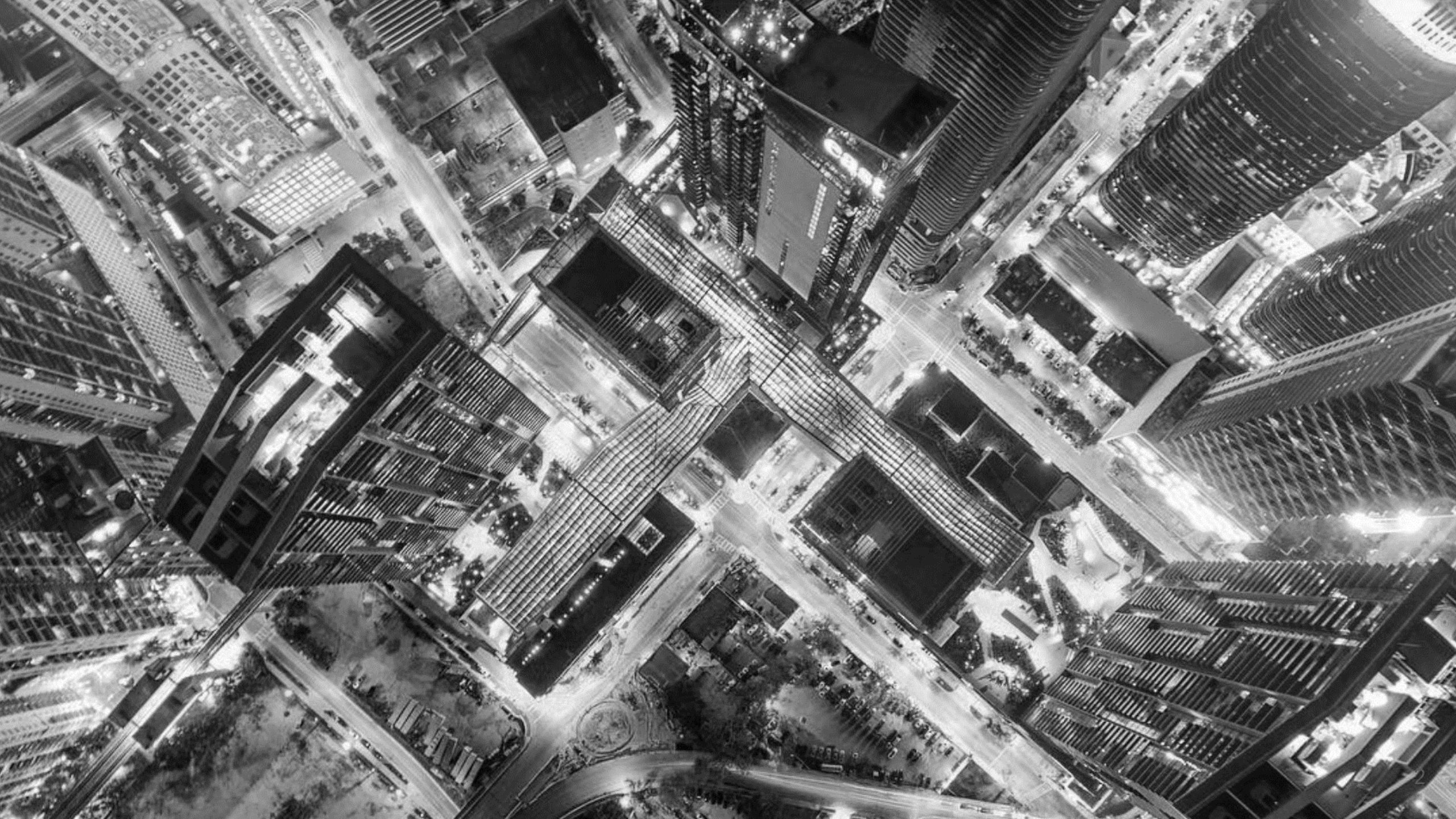



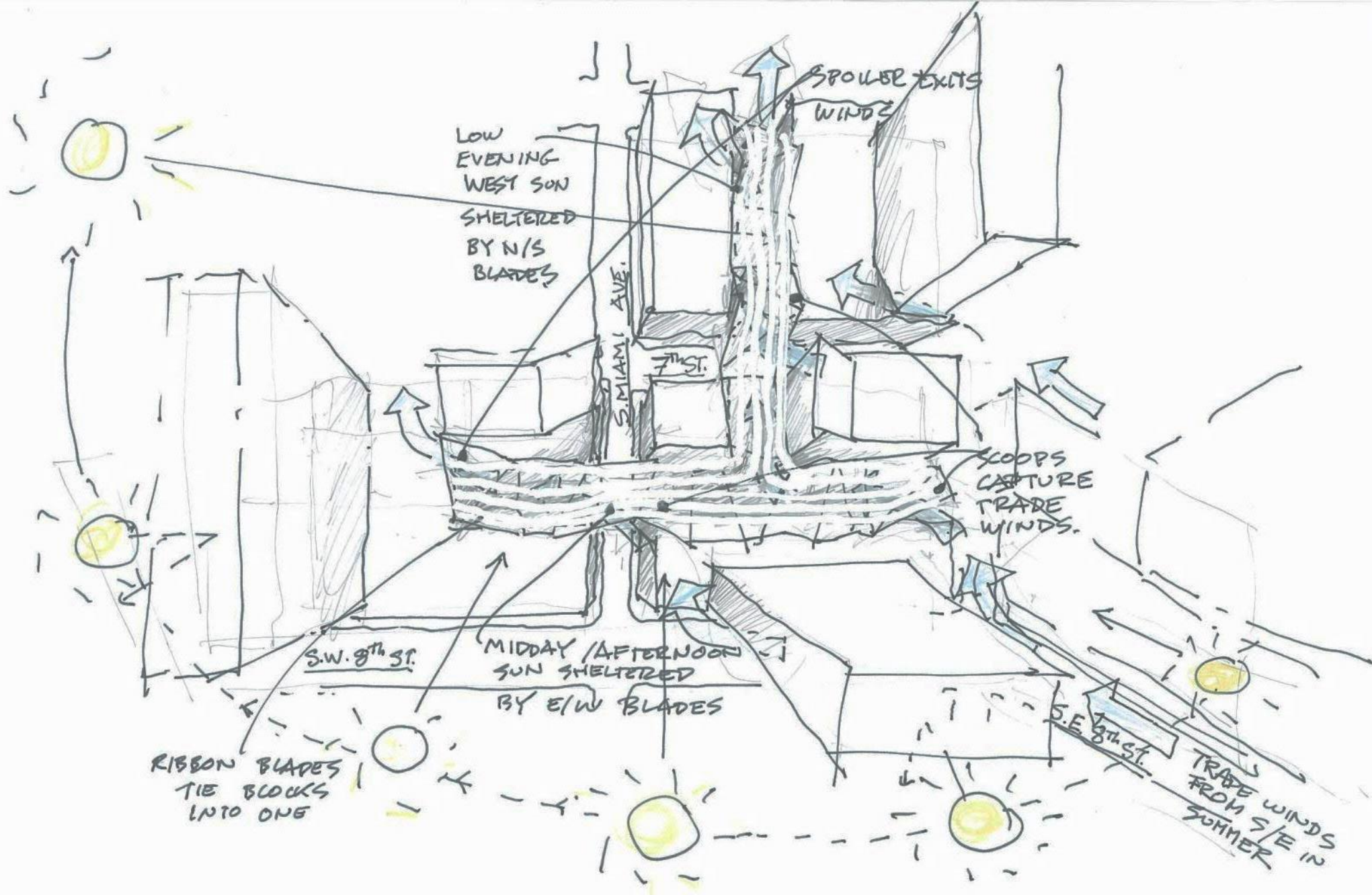

15.706
12.824
9.968
0

Length: 791.961 (m)
Width: 549.122 (m)
Height: 78.759 (m)
Wood size: 2.188 (m)

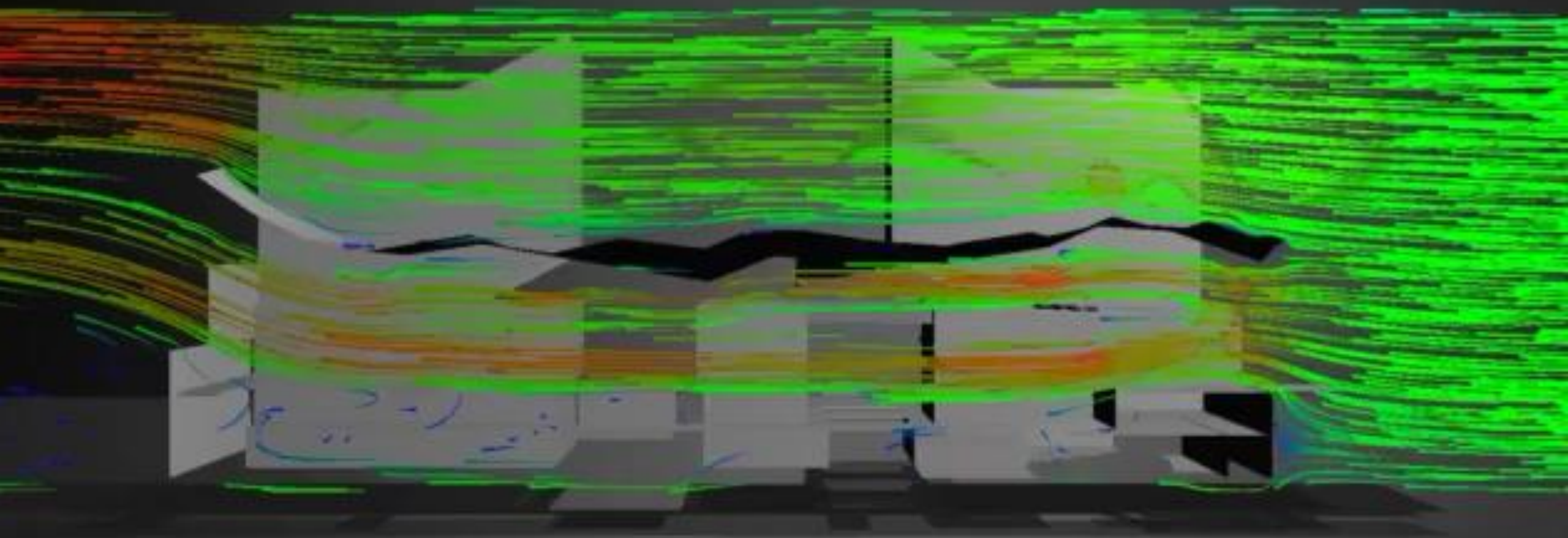

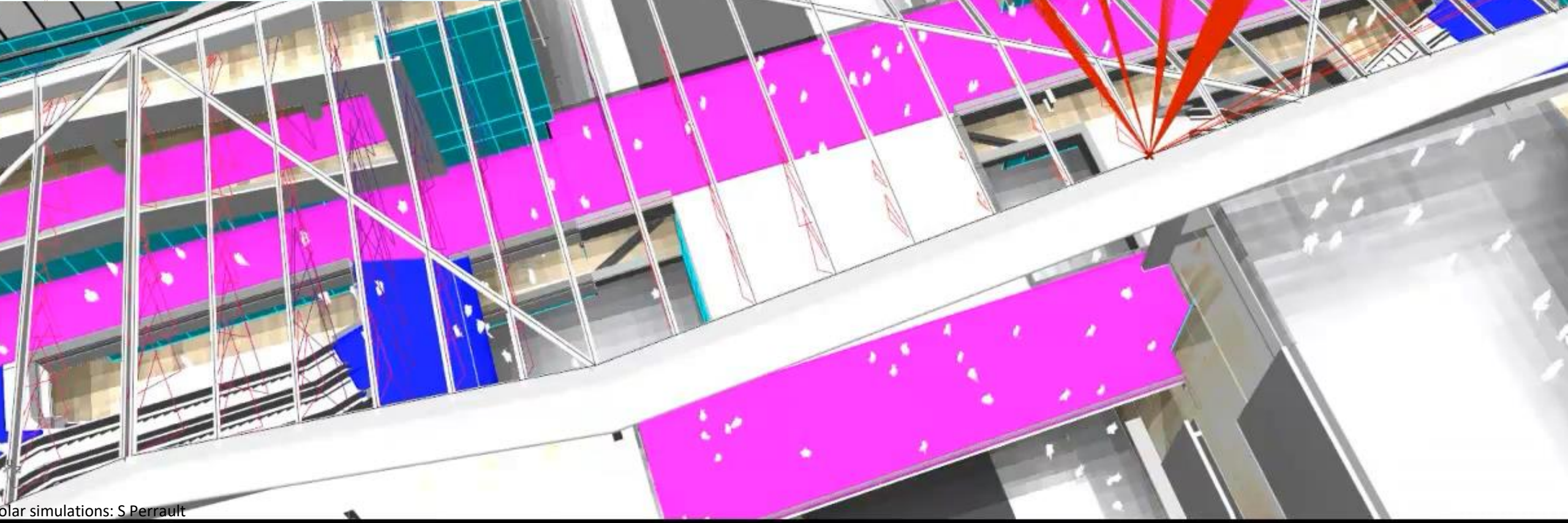
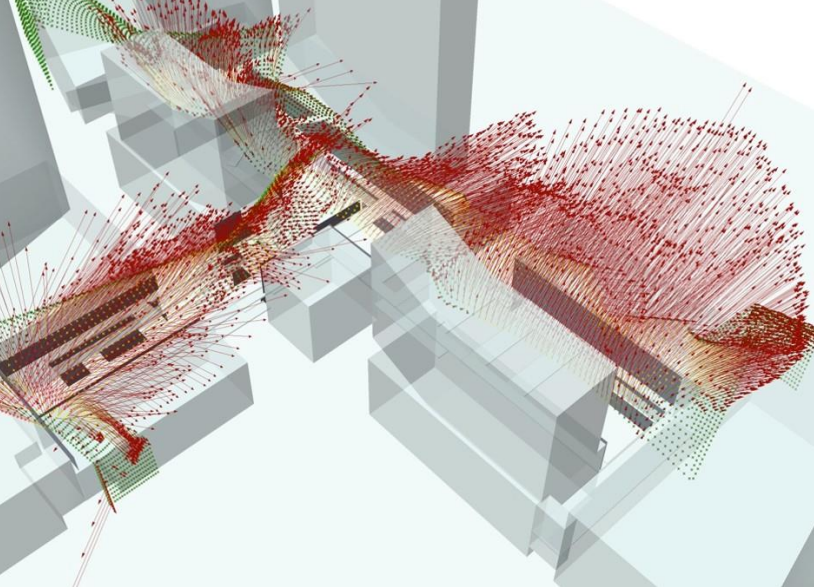



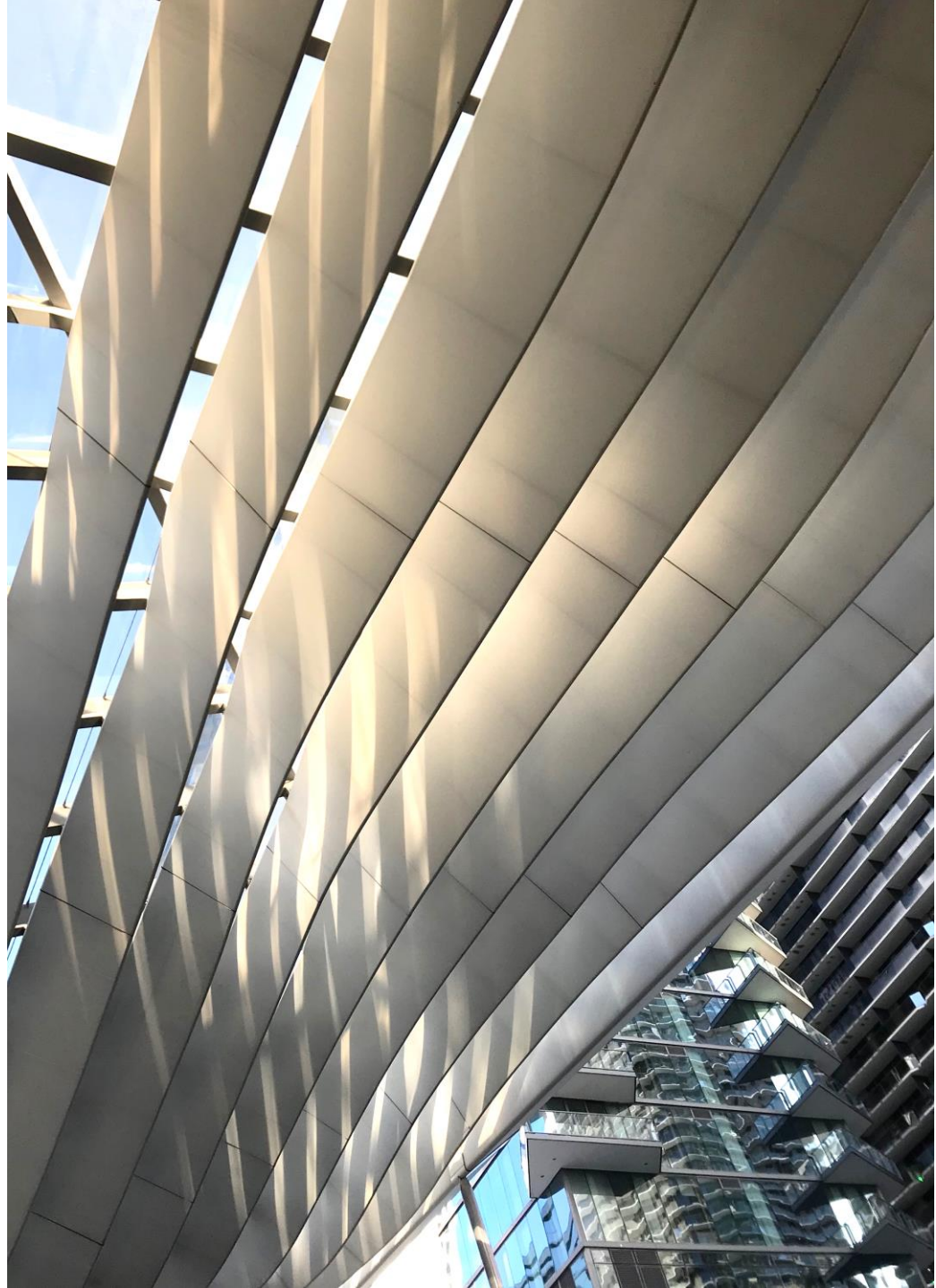

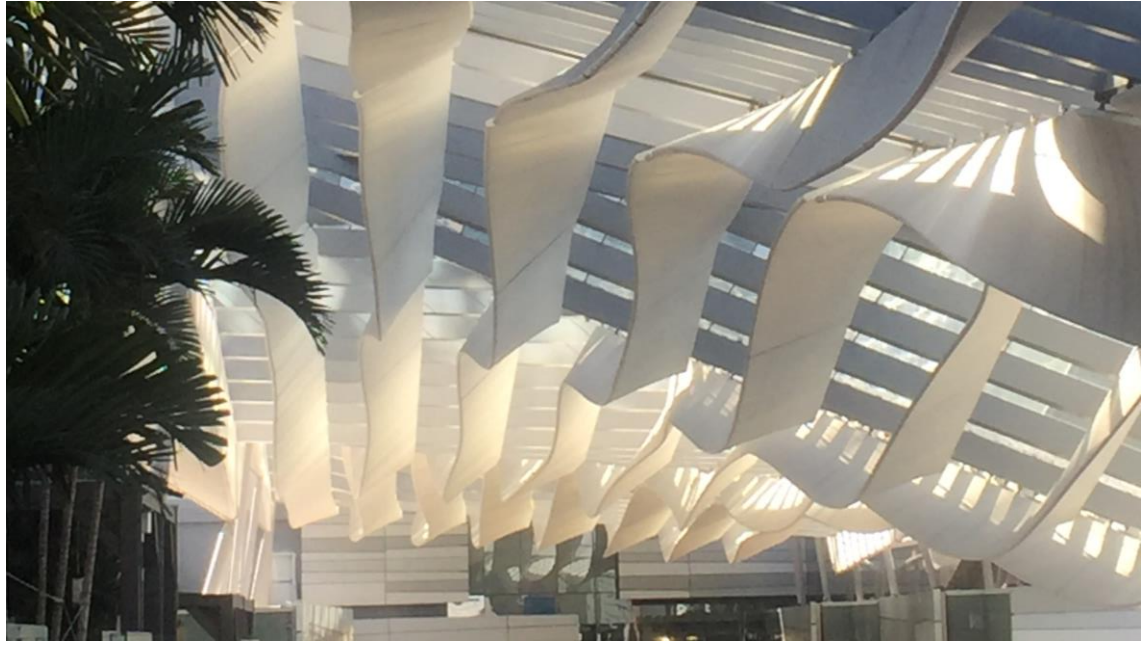





PANDORA

PANDORA

DE SMOOD OPENING HOUTEN



World Diamonds, EPL opening soon

EPL THE EXPERIMENTAL
World Diamond EPL opening soon

PANDORA

VICTORIA'S SECRET

FREE

20% FREE

HDA

HUGH DUTTON ASSOCIÉS

CENTRE DES
MONUMENTS NATIONAUX



2b
dm
Architecture
& Patrimoine



**HÔTEL DE LA MARINE COUR DE L'INTENDANT -SKYLIGHT
A DAYLIGHT CHANDELIER**





ÉTAGES
AJOUTÉS AU
MILIEU DU XIXE

ÉTAGES
CONSTRUITS
À LA FIN DU
XVIII SIECLE

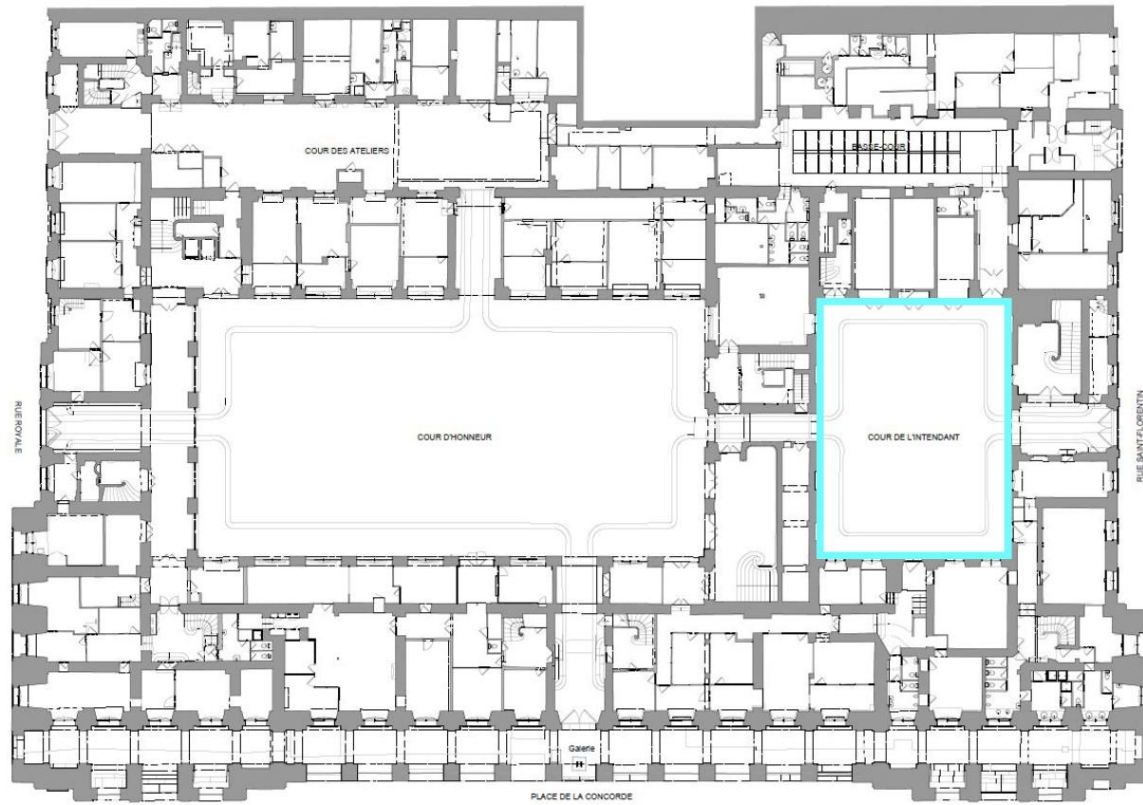

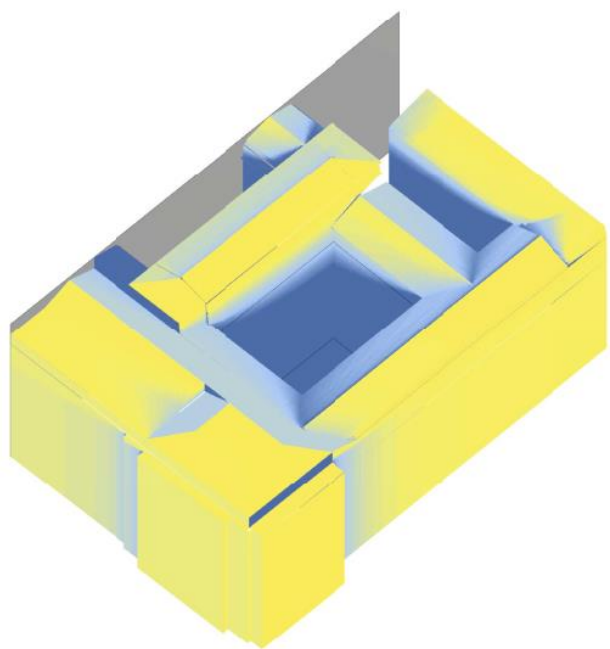

21 DÉCEMBRE

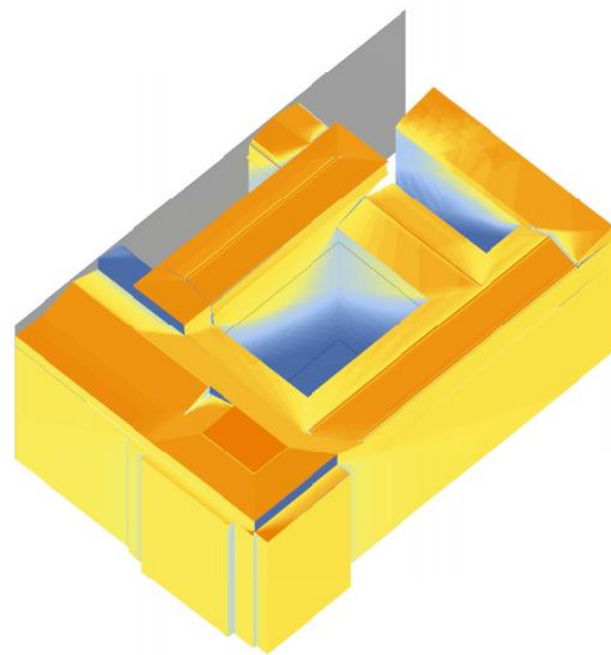

21 MARS

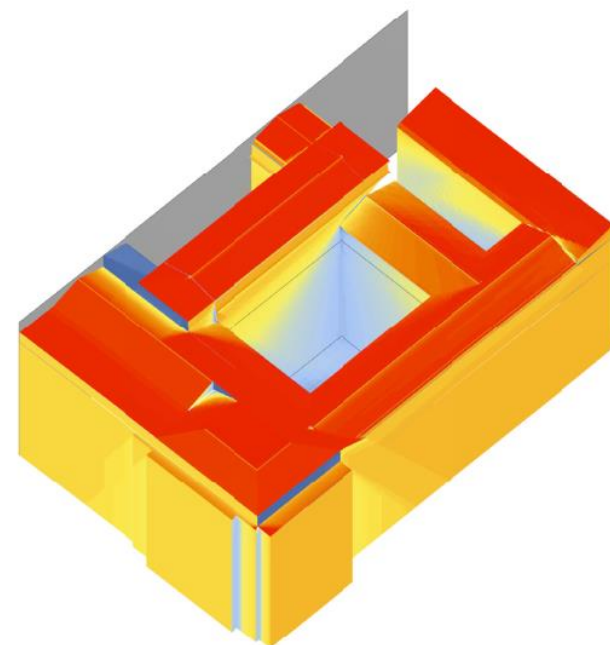

21 JUIN

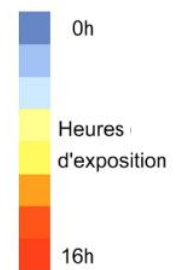

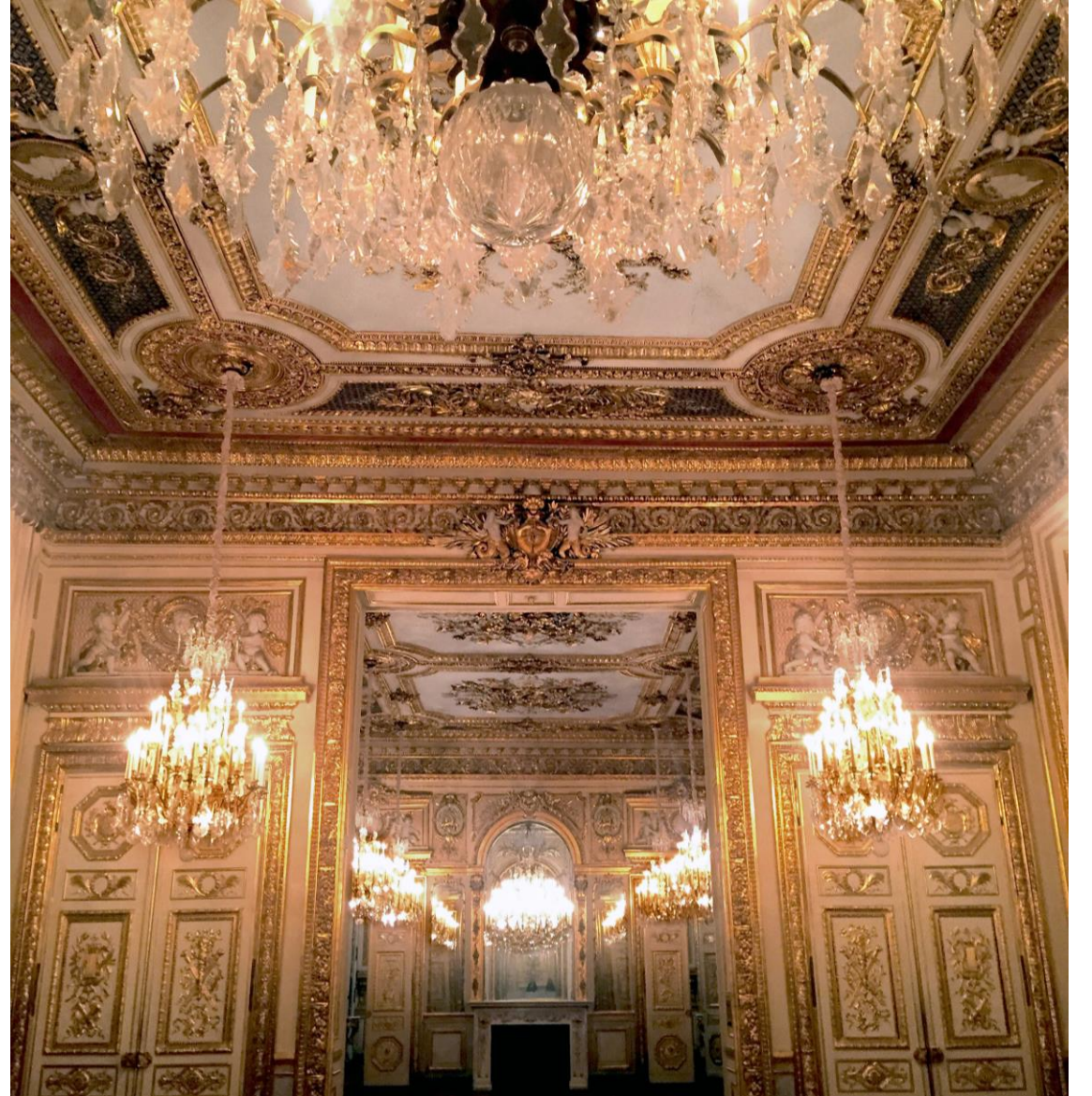



INTENTIONS
TAILLE DES JOYAUX, GÉOMÉTRIE ET FACETTES

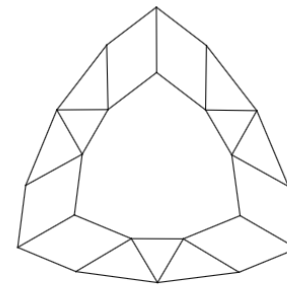
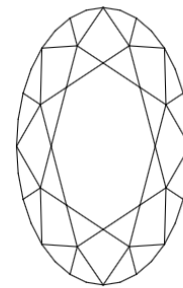
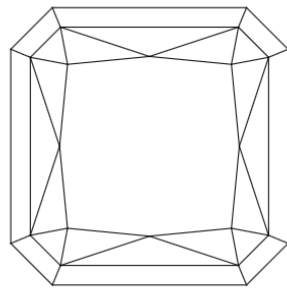
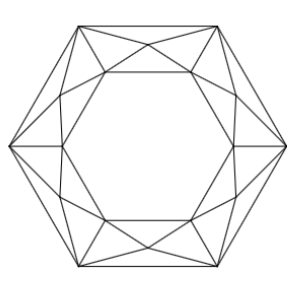
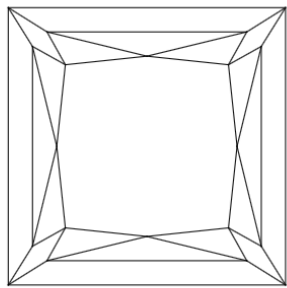
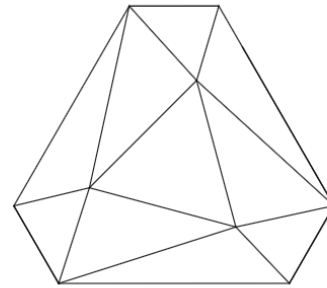
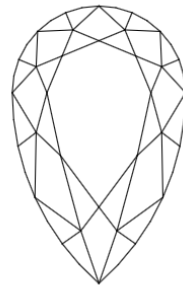
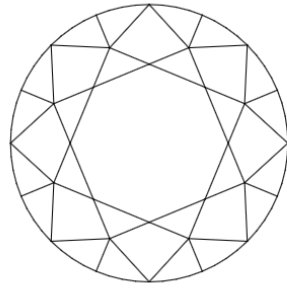
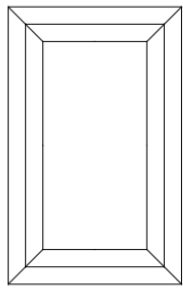
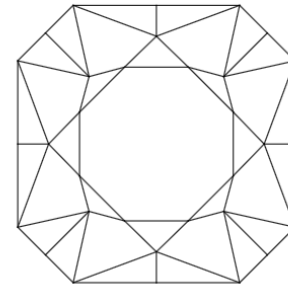
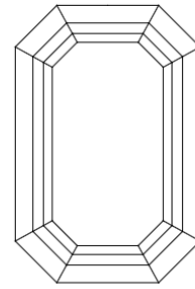
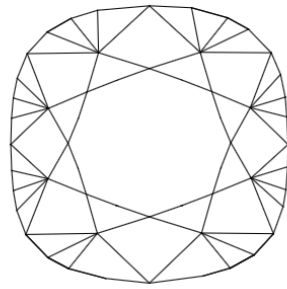
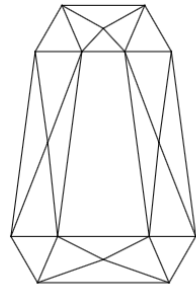
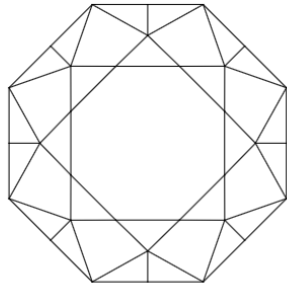

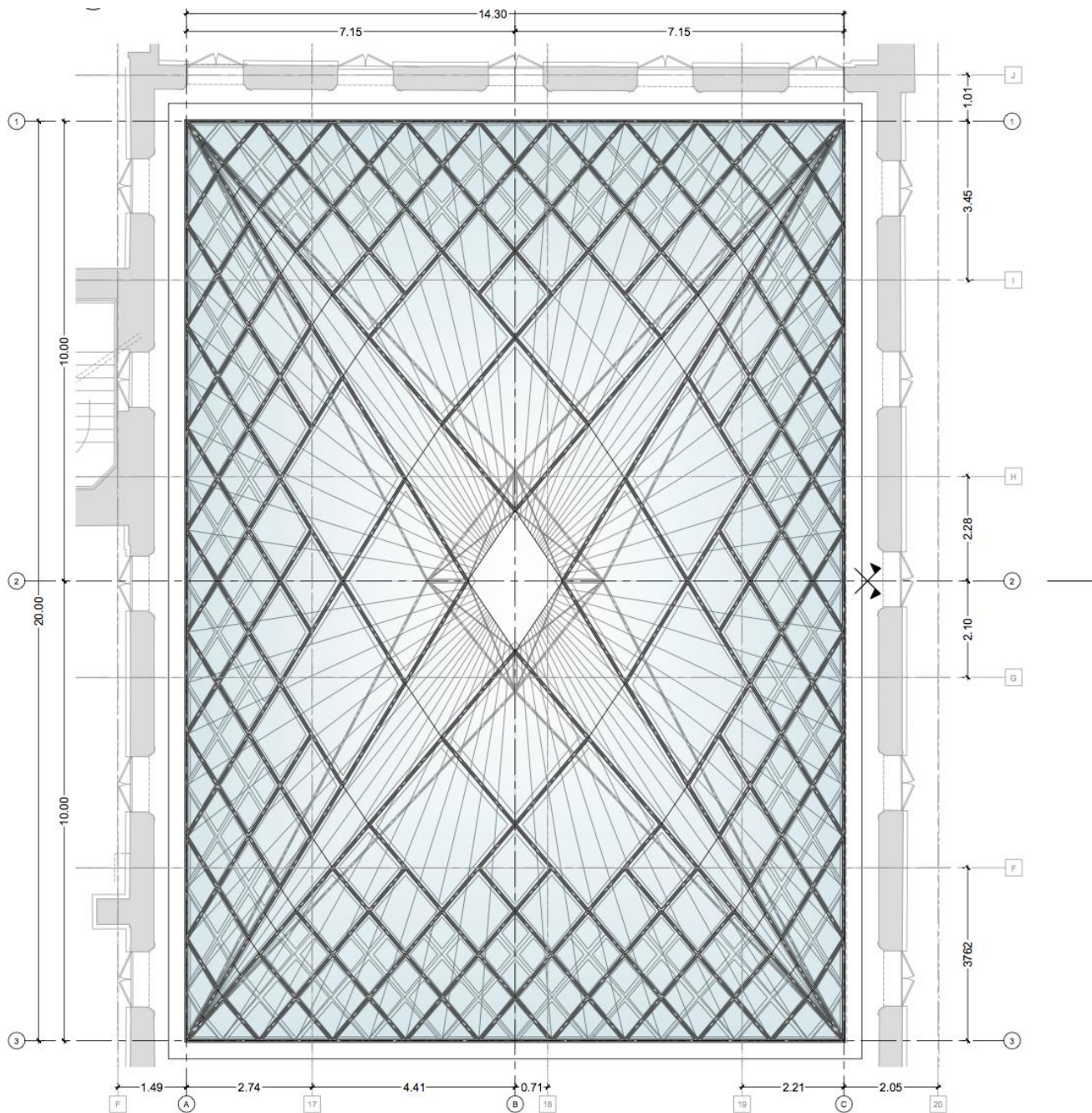



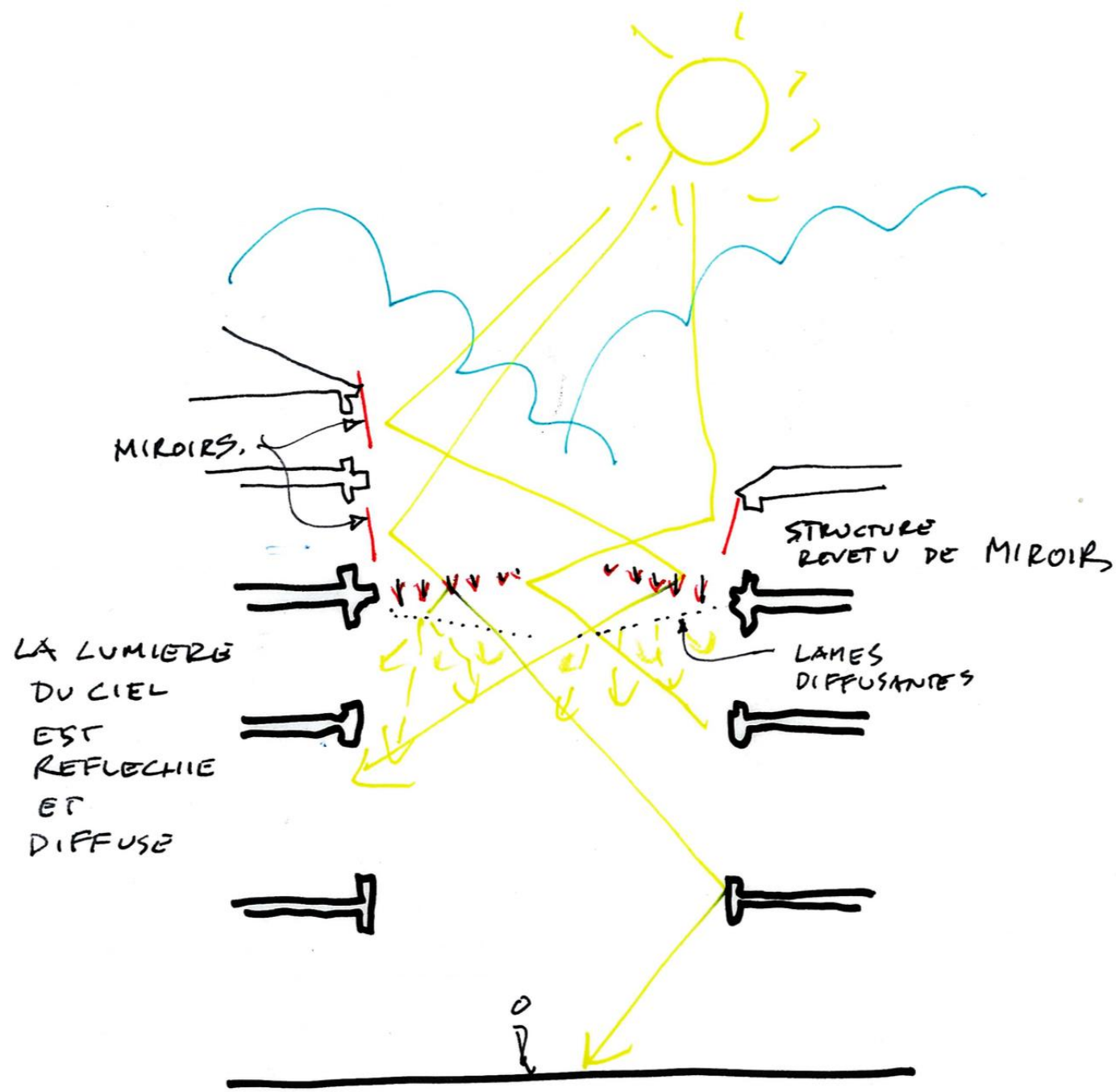

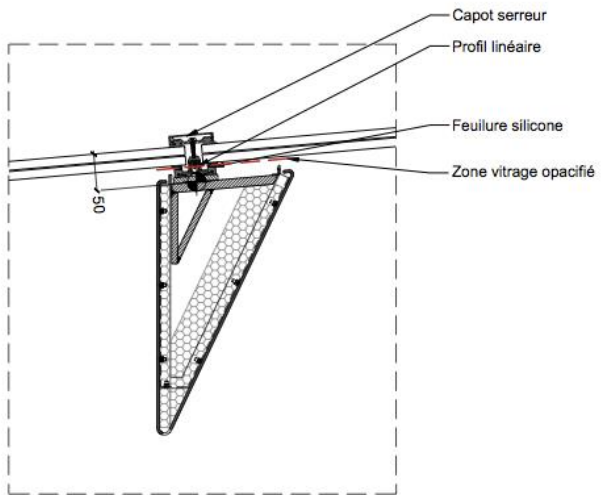

03 DETAIL SUPPORT DU VERRE
 ECHELLE: 1/10

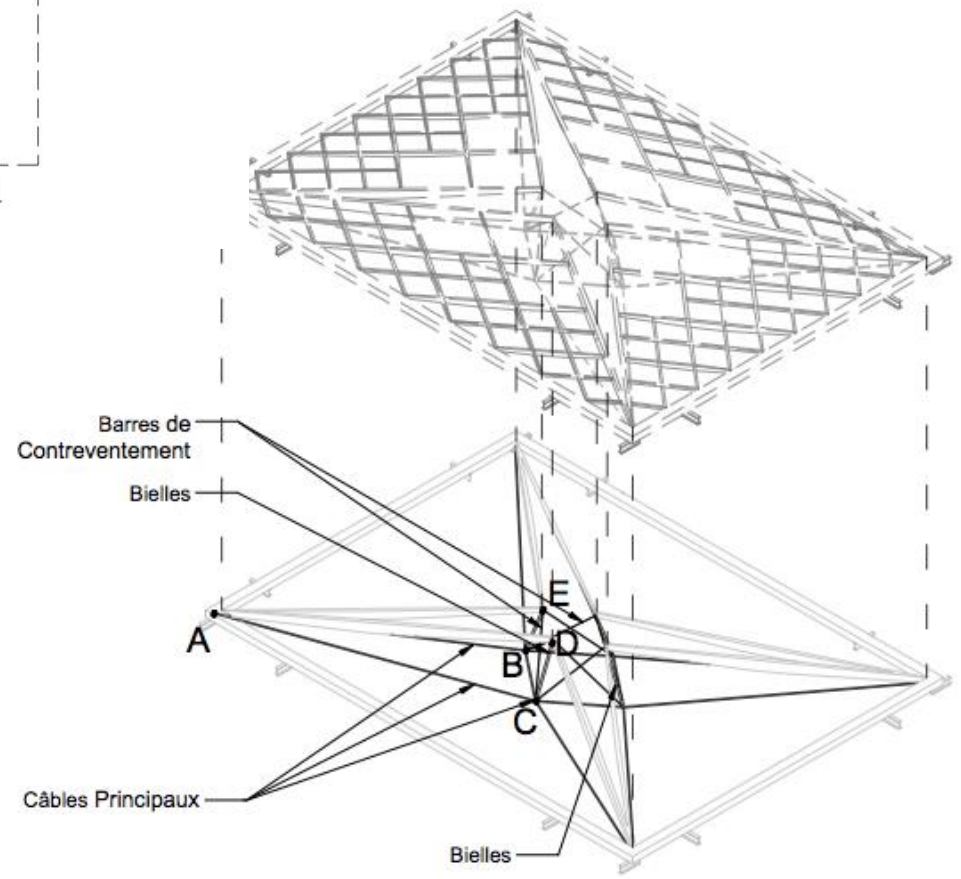

04 VUE PERSPECTIVE GEOMETRIE CABLES

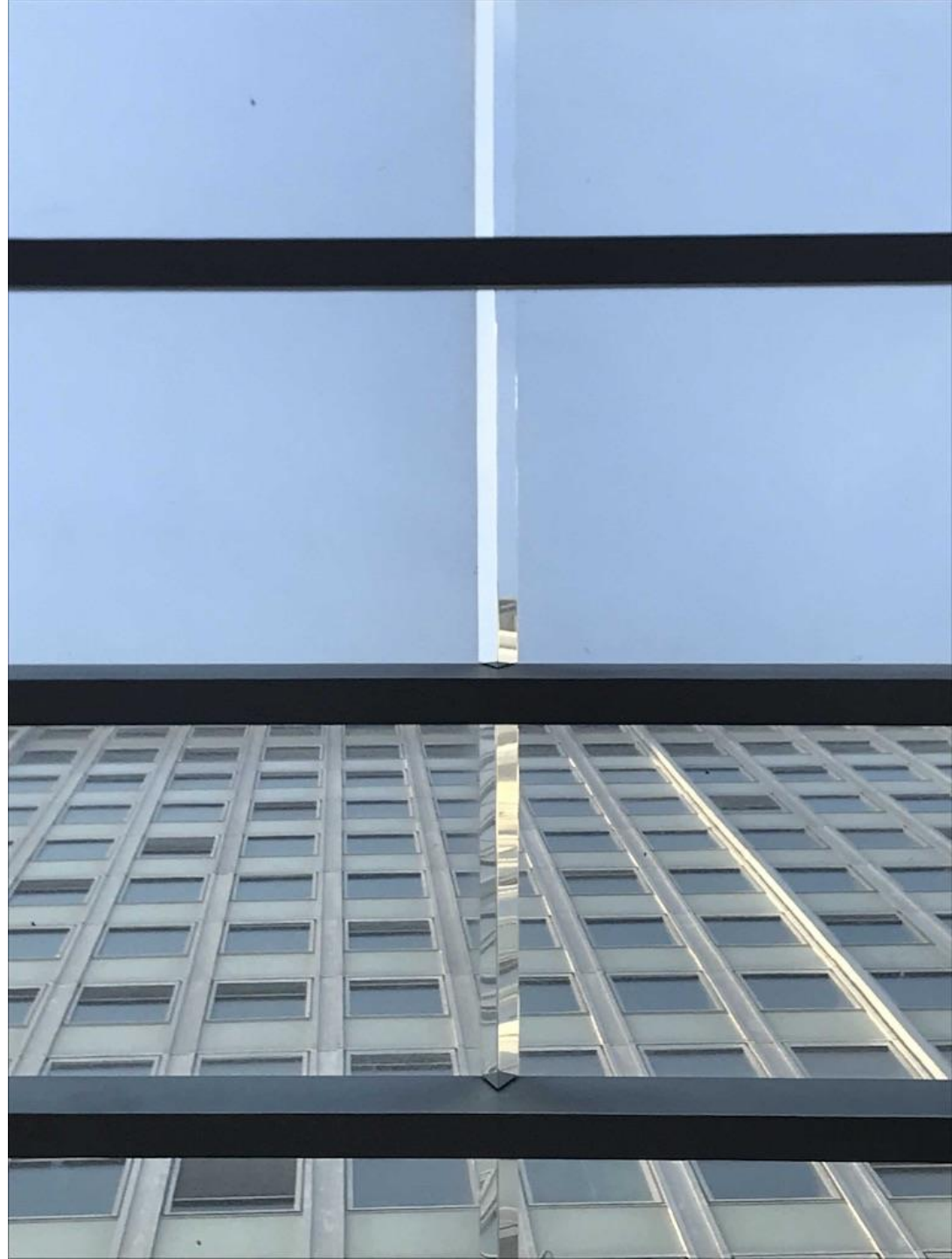

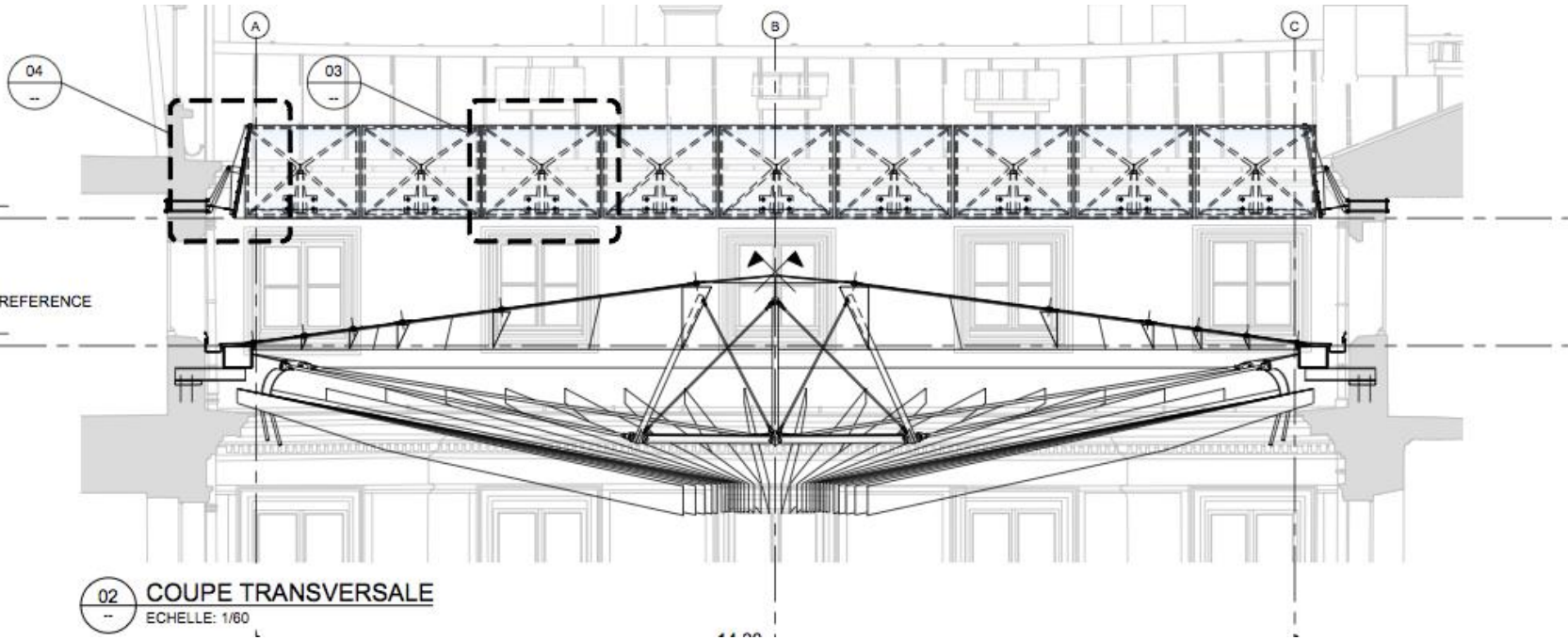
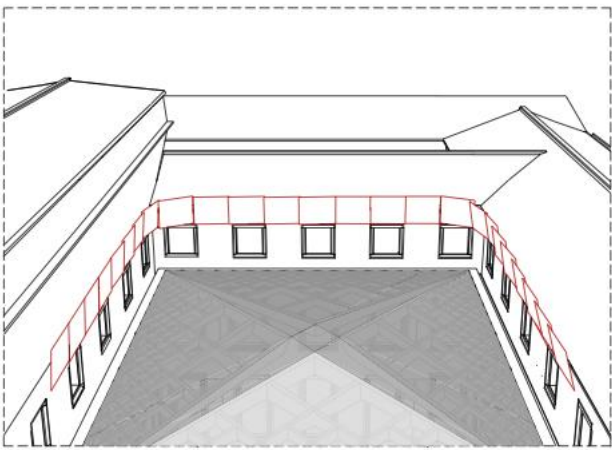

02 COUPE TRANSVERSALE
ECHELLE: 1/60

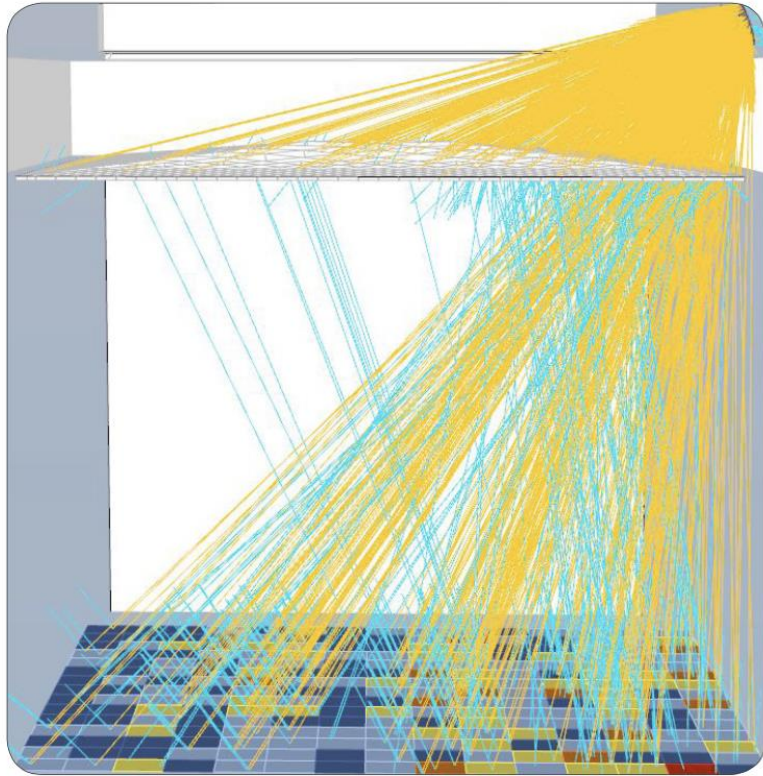

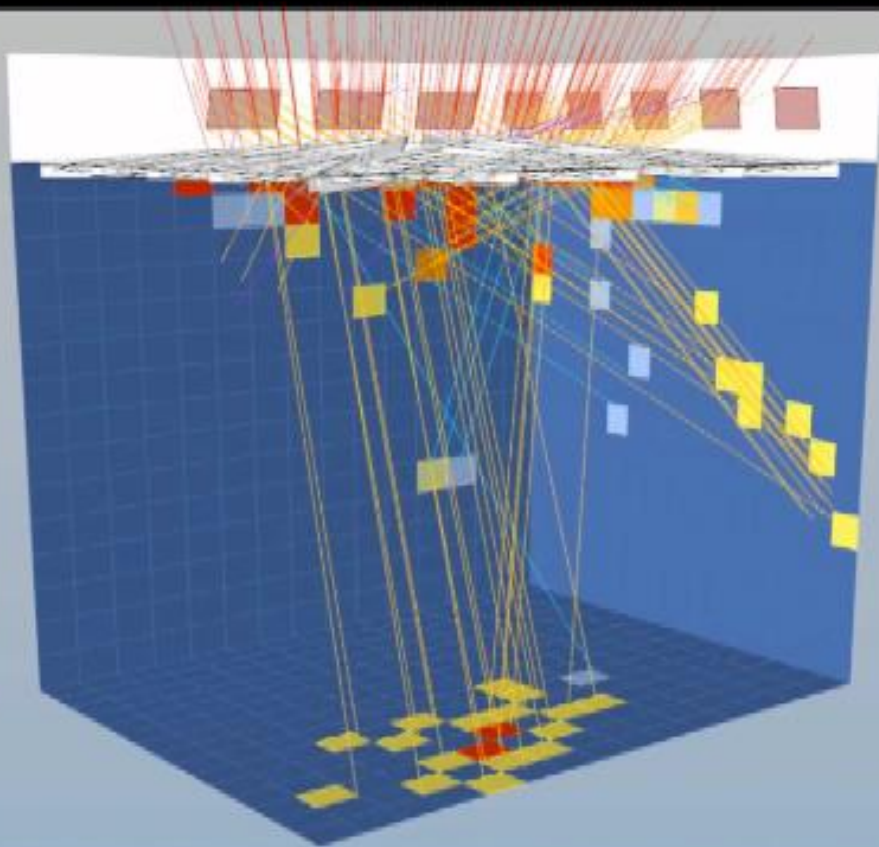

21 JAN 11:12

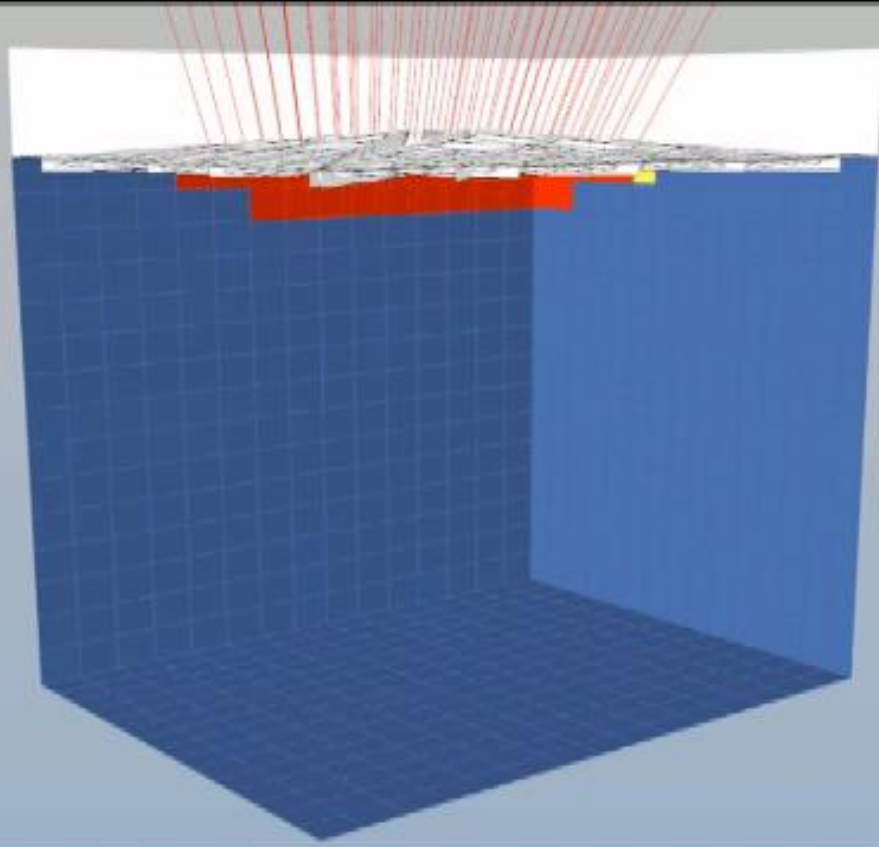

21 JAN 11:12



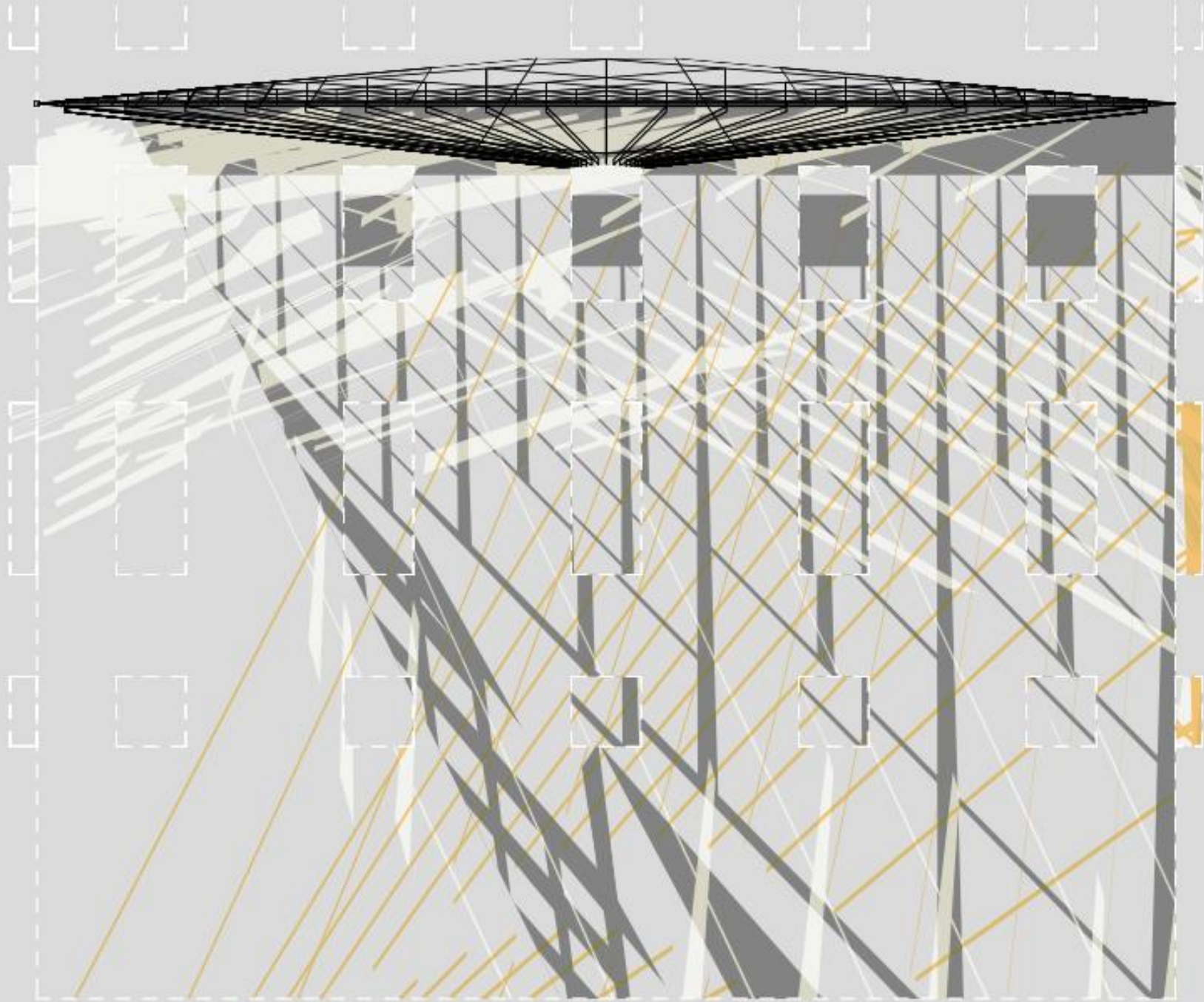

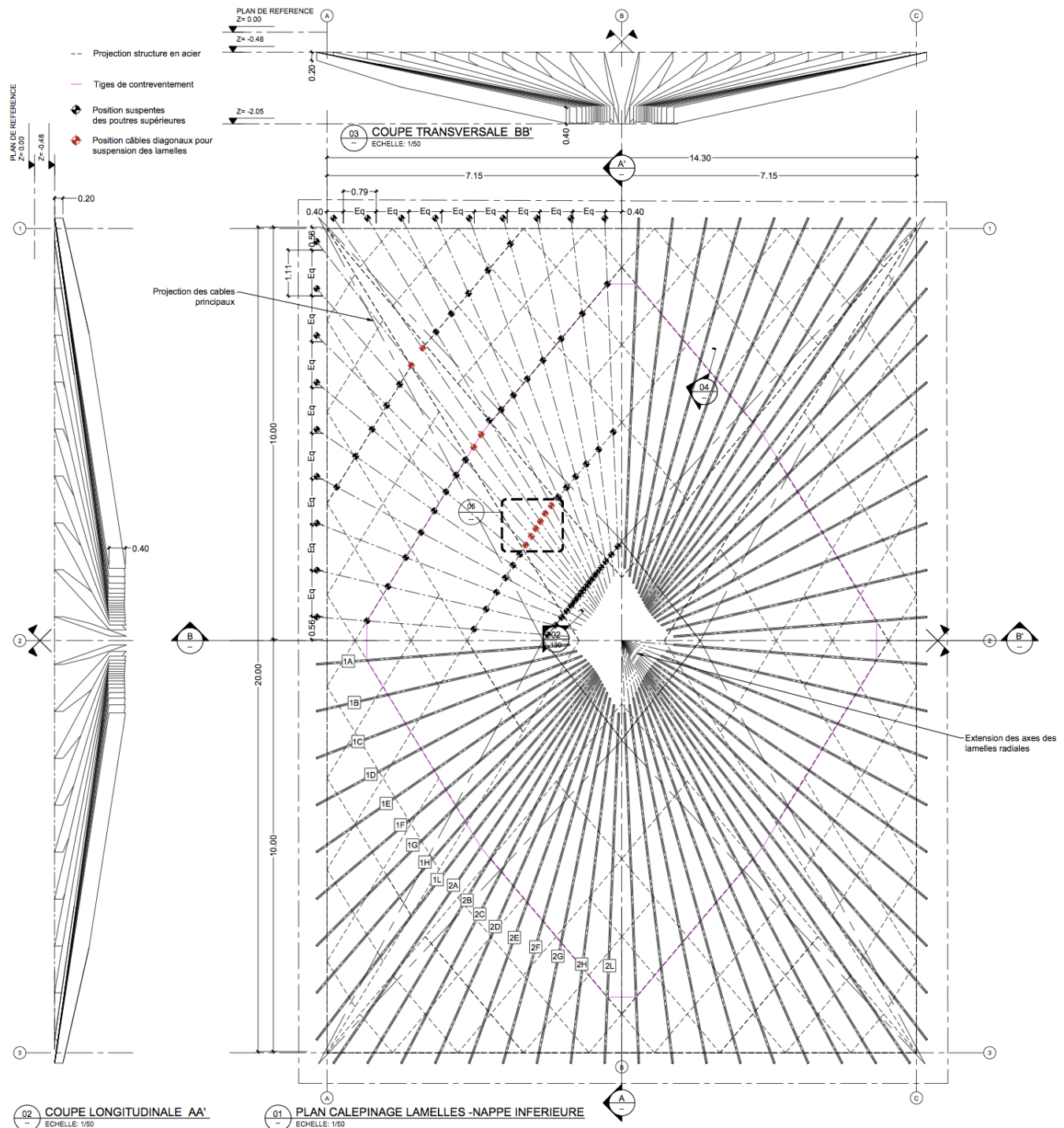

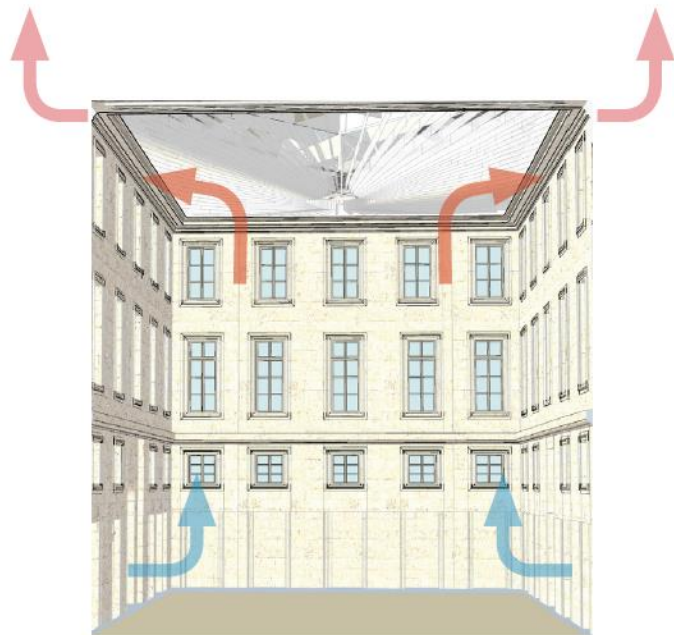

ÉTÉ

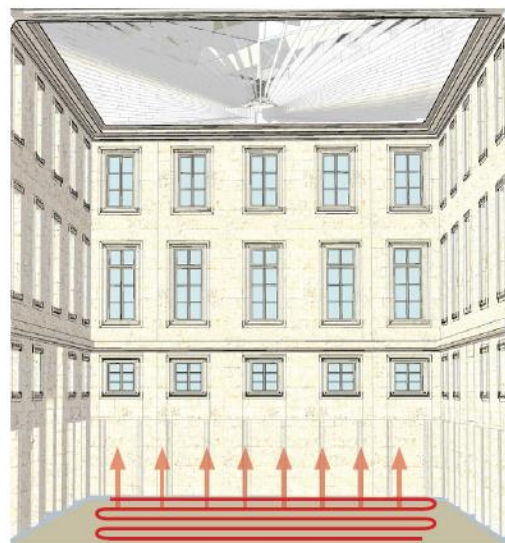

HIVER

